

PUBLIC WORKS DEPARTMENT
STANDARD DRAWINGS



PUBLIC WORKS DEPARTMENT STANDARD DRAWINGS

DRAWING NO.	DRAWING TITLE	VERSION
SD00	Index of Standard Drawings	August - 16
SD01	Gravel Wearing Course (6m) Arterial Road	August - 16
SD02	Gravel Wearing Course (5m) Arterial Road	August - 16
SD03	Gravel Wearing Course (4m) Arterial Road	August - 16
SD04	Gravel Wearing Course (3m) Arterial or Feeder Road	August - 16
SD05	Gravel Wearing Course (2.5m) Arterial or Feeder Road	August - 16
SD06	Bitumen Wearing Course (8m) Arterial Road	August - 16
SD06/a	Bitumen Wearing Course (8m) - Details Arterial Road	August - 16
SD07	Bitumen Wearing Course (7m) Arterial Road	August - 16
SD07/a	Bitumen Wearing Course (7m) - Details Arterial Road	August - 16
SD08	Bitumen Wearing Course (7m) Urban Road with Kerb	August - 16
SD09	Hill Road (4m) Arterial Road	August - 16
SD10	Concrete Pavement	August - 16
SD10/a	Concrete Pavement - Details	August - 16
SD11	Strip Concrete Pavement	August - 16
SD11/a	Strip Concrete Pavement - Details	August - 16
SD12	Stone Pavement	August - 16
SD13	Concrete Drift Plan & Section	August - 16
SD13/a	Concrete Drift Section BB & Details	August - 16
SD14	Grouted Stone or Dry Stone Packed Drift Plan & Section	August - 16
SD14/a	Grouted Stone or Dry Stone Packed Drift Section BB	August - 16

DRAWING NO.	DRAWING TITLE	VERSION
SD15	Gabion Retaining Wall and Land Protection	August - 16
SD16	Typical Mortared Random Rubble masonry Retaining Wall	August - 16
SD17	Typical Drawings for Drainage (Line drain/ unlined drain)	August - 16
SD18	Box Culvert (1mx1m)	August - 16
SD18/a	Box Culvert (1mx1m) Reinforcement Details 1	August - 16
SD18/b	Box Culvert (1mx1m) Reinforcement Details 2	August - 16
SD18/d	Box Culvert (1mx1m) Bar Bending Schedule 1	August - 16
SD18/e	Box Culvert (1mx1m) Bar Bending Schedule 2	August - 16
SD19	Typical Drawings for 1,050mm Pipe Culvert Single & Double, Reinforcement Details	August - 16
SD19/a	Typical Drawings for 1,050mm Pipe Culvert Triple, Reinforcement Details	August - 16
SD19/b	Typical Drawings for 1,050mm Pipe Culvert Single & Double, Elevation & Plan	August - 16
SD19/c	Typical Drawings for 1,050mm Pipe Culvert Details	August - 16
SD19/d	Typical Drawings for 1,050mm Pipe Culvert Single & Double, General and Section Views	August - 16
SD19/e	Typical Drawings for 1,050mm Pipe Culvert Triple, Section	August - 16
SD19/f	Typical Drawings for 1,050mm Pipe Culvert Apron, Head & Wing Wall Reinforcement Details	August - 16
SD20	Check Dam and Scour Check	August - 16
SD21	Road Safety Speed Hump A	August - 16

	DESIGNED BY:	JH
	CAD BY:	HA
	REVISED BY:	AP
2.	REVIEW	08/16
1.	ORIGINAL ISSUE	09/12
No.	DESCRIPTION	DATE
	APPROVED BY:	SN



Public Works Department

Private Mail Bag 9044

Tel:22888 / 33460

PWD Standard Drawings

DRAWING TITLE : INDEX OF STANDARD DRAWINGS

SD00

SCALE : NTS DATE : May 2017 DRAWING NUMBER

GENERAL NOTES:

1. All dimensions are in millimetres unless otherwise stated
2. Do not scale from drawing
3. Road reserved shall be 30m for Arterial and 20m for Urban and Feeder roads.
4. All gravel material shall be approved by engineer prior to delivery to site
5. Base course and sub base course shall be conformed with California Bearing Ratio (CBR) value.
6. Sub-base shall have a 4 day soaked CBR of not less than 50% at 98% Maximum Dry Density (MDD) and road base shall have a 4 day soaked CBR of not less than 80% at 98% of MDD. Subgrade CBR shall not be less than 8% CBR at 95% MDD.
7. Miter drain shall be provided at least 100m interval in both side of road

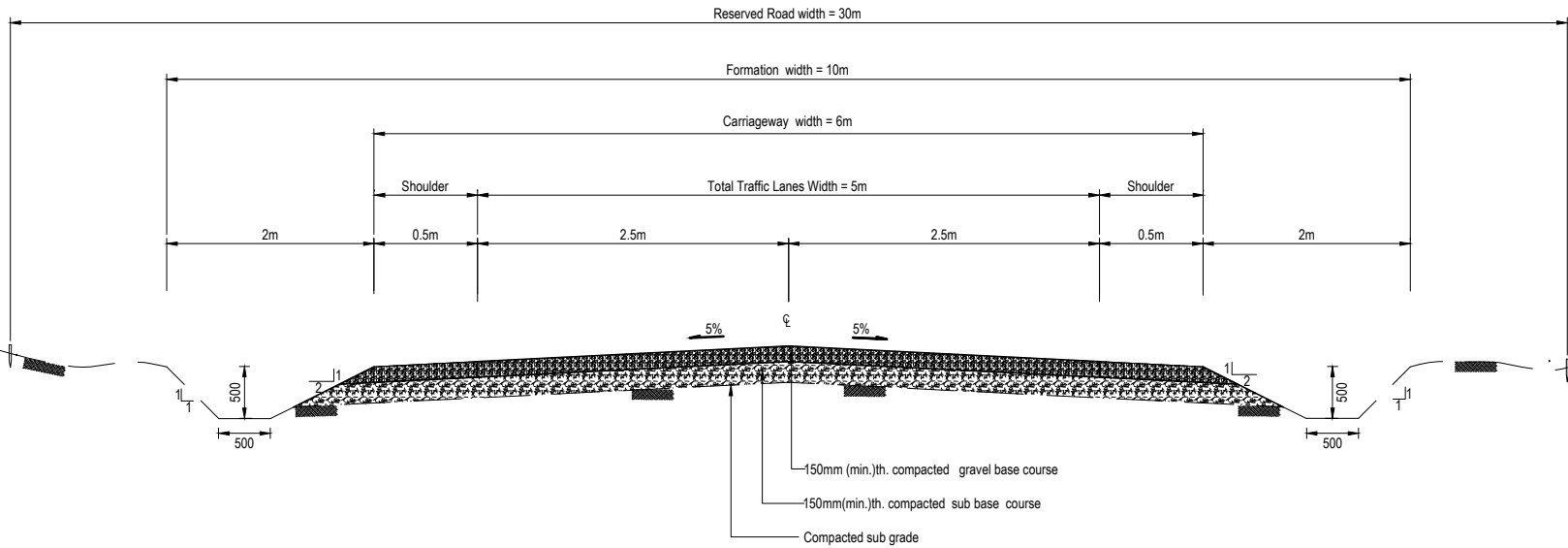

TYPICAL CROSS SECTION
(>500 ADT)

			DESIGNED BY:	JH	 <p>Public Works Department Private Mail Bag 9044 Tel: 22888 / 33460</p>	PWD Standard Drawings		
			CAD BY:	HA				
			REVISED BY:	AP		DRAWING TITLE: Gravel Wearing Course (6m) Arterial Road		
			APPROVED BY:	SN		SCALE: 1:50	DATE: May 2017	DRAWING NUMBER
No.	DESCRIPTION	DATE						
2.	REVIEW	08/16						
1.	ORIGINAL ISSUE	09/12						

GENERAL NOTES:

1. All dimensions are in millimetres unless otherwise stated
2. Do not scale from drawing
3. Road reserved shall be 30m for Arterial and 20m for Urban and Feeder roads.
4. All gravel material shall be approved by engineer prior to delivery to site
5. Base course and sub base course shall be conformed with California Bearing Ratio (CBR) value.
6. Sub-base shall have a 4 day soaked CBR of not less than 50% at 98% Maximum Dry Density (MDD) and road base shall have a 4 day soaked CBR of not less than 80% at 98% of MDD. Subgrade CBR shall not be less than 8% CBR at 95% MDD.
7. Miter drain shall be provided at least 100m interval in both side of road

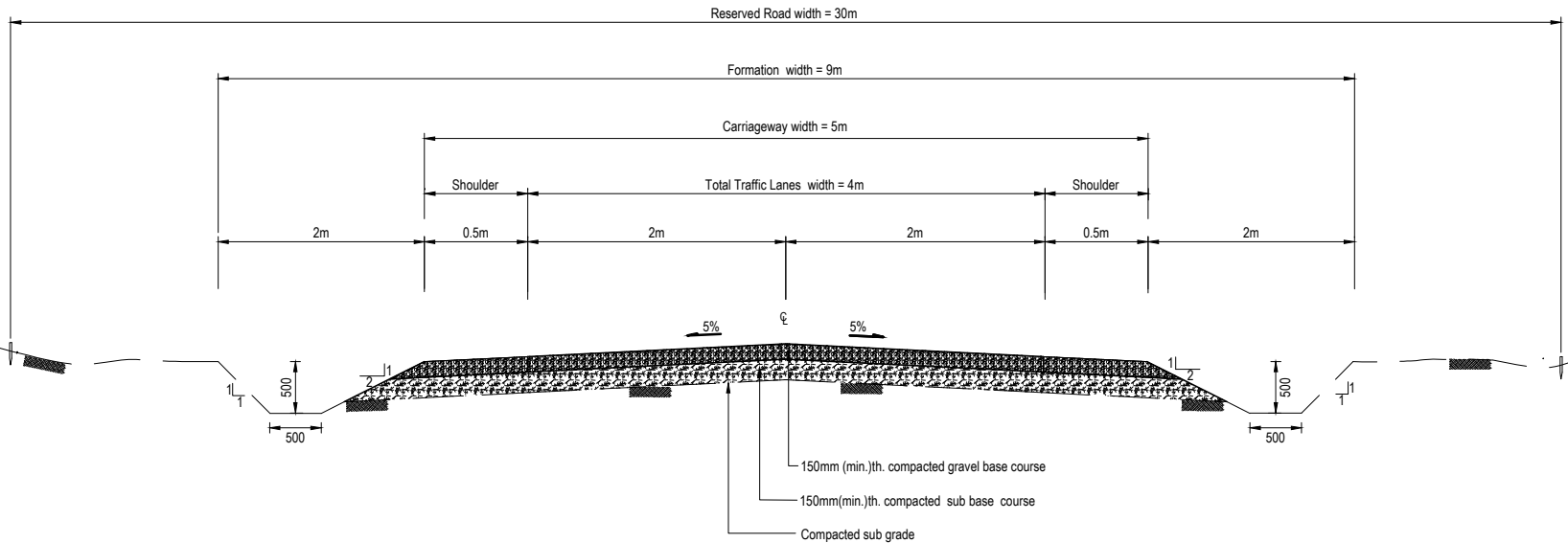

TYPICAL CROSS SECTION

(200-500 ADT)

			DESIGNED BY:	JH	 Public Works Department Private Mail Bag 9044 Tel: 22888 / 33460	PWD Standard Drawings			
			CAD BY:	HA		DRAWING TITLE :	Gravel Wearing Course (5m) Arterial Road		SD02
			REVISED BY:	AP		SCALE :	1:50	DATE :	
2.	REVIEW	08/16	APPROVED BY:	SN				DRAWING NUMBER	
1.	ORIGINAL ISSUE	09/12							
No.	DESCRIPTION	DATE							

GENERAL NOTES:

1. All dimensions are in millimetres unless otherwise stated
2. Do not scale from drawing
3. Road reserved shall be 30m for Arterial and 20m for Urban and Feeder roads.
4. All gravel material shall be approved by engineer prior to delivery to site
5. Base course and sub base course shall be conformed with California Bearing Ratio (CBR) value.
6. Sub-base shall have a 4 day soaked CBR of not less than 50% at 98% Maximum Dry Density (MDD) and road base shall have a 4 day soaked CBR of not less than 80% at 98% of MDD. Subgrade CBR shall not be less than 8% CBR at 95% MDD.
7. Miter drain shall be provided at least 100m interval in both side of road

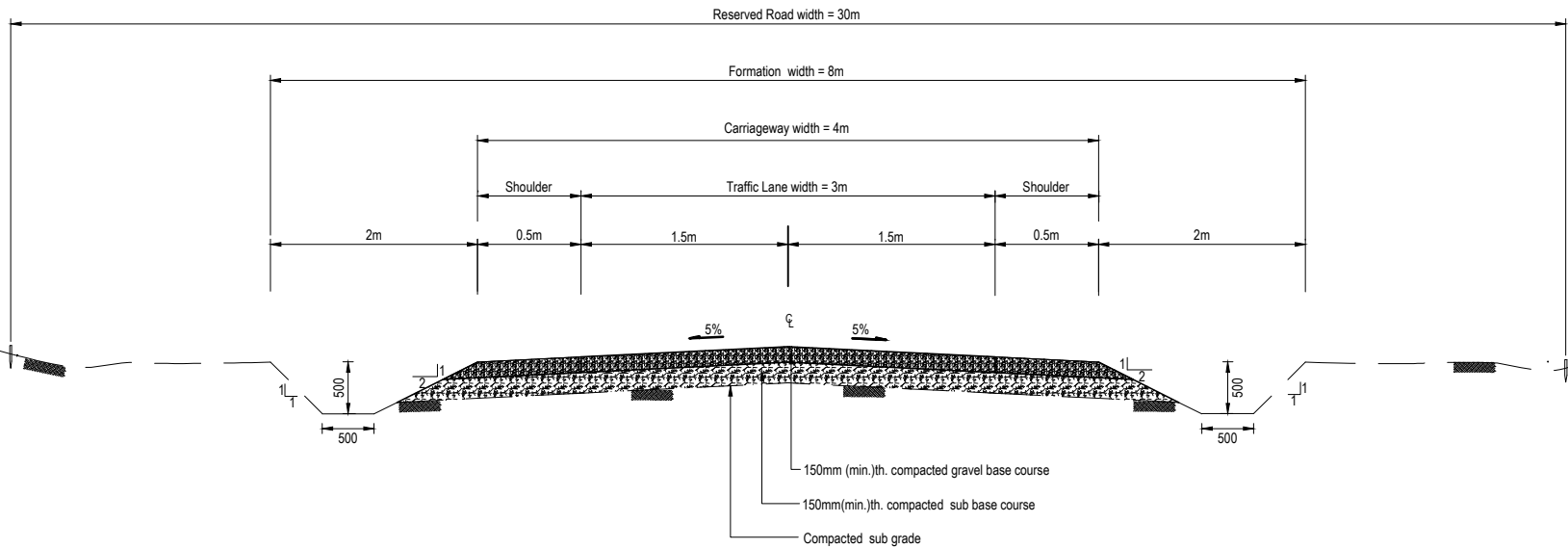

TYPICAL CROSS SECTION

(50-200 ADT)

			DESIGNED BY:	JH	 <p>Public Works Department Private Mail Bag 9044 Tel: 22888 / 33460</p>	PWD Standard Drawings		
			CAD BY:	HA				
			REVISED BY:	AP		SCALE : 1:50	DATE : May 2017	DRAWING NUMBER
2.	REVIEW	08/16	APPROVED BY:	SN				
1.	ORIGINAL ISSUE	09/12						
No.	DESCRIPTION	DATE						

GENERAL NOTES:

1. All dimensions are in millimetres unless otherwise stated
2. Do not scale from drawing
3. Road reserved shall be 30m for Arterial and 20m for Urban and Feeder roads.
4. All gravel material shall be approved by engineer prior to delivery to site
5. Base course and sub base course shall be conformed with California Bearing Ratio (CBR) value.
6. Sub-base shall have a 4 day soaked CBR of not less than 50% at 98% Maximum Dry Density (MDD) and road base shall have a 4 day soaked CBR of not less than 80% at 98% of MDD. Subgrade CBR shall not be less than 8% CBR at 95% MDD.
7. Miter drain shall be provided at least 100m interval in both side of road

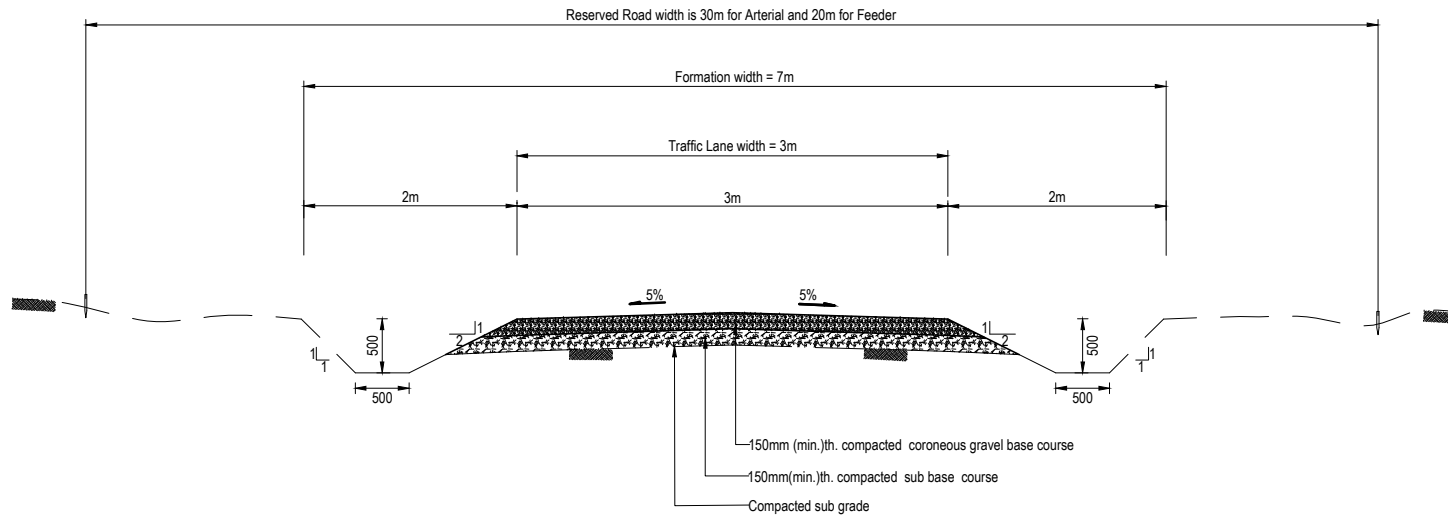

TYPICAL CROSS SECTION
(20-50 ADT)

			DESIGNED BY:	JH
			CAD BY:	HA
			REVISED BY:	AP
2.	REVIEW	08/16	APPROVED BY:	SN
1.	ORIGINAL ISSUE	09/12		
No.	DESCRIPTION	DATE		



Public Works Department

Private Mail Bag 9044

Tel: 22888 / 33460

PWD Standard Drawings

DRAWING TITLE : Gravel Wearing Course (3m) Arterial or Feeder Road			SD04
SCALE : 1:50	DATE : May 2017	DRAWING NUMBER	

GENERAL NOTES:

1. All dimensions are in millimetres unless otherwise stated
2. Do not scale from drawing
3. Road reserved shall be 30m for Arterial and 20m for Urban and Feeder roads.
4. All gravel material shall be approved by engineer prior to delivery to site
5. Base course and sub base course shall be conformed with California Bearing Ratio (CBR) value.
6. Sub-base shall have a 4 day soaked CBR of not less than 50% at 98% Maximum Dry Density (MDD) and road base shall have a 4 day soaked CBR of not less than 80% at 98% of MDD. Subgrade CBR shall not be less than 8% CBR at 95% MDD.
7. Miter drain shall be provided at least 100m interval in both side of road

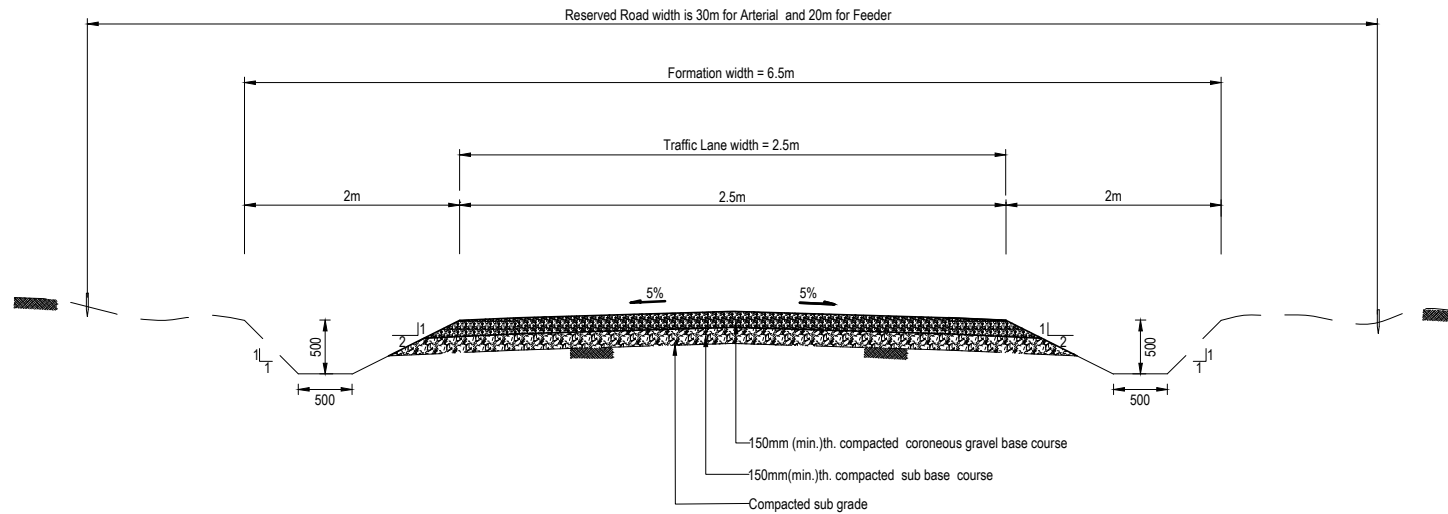

TYPICAL CROSS SECTION

(< 20 ADT)

			DESIGNED BY:	JH
			CAD BY:	HA
			REVISED BY:	AP
2.	REVIEW	08/16	APPROVED BY:	SN
1.	ORIGINAL ISSUE	09/12		
No.	DESCRIPTION	DATE		



Public Works Department

Private Mail Bag 9044

Tel: 22888 / 33460

PWD Standard Drawings

DRAWING TITLE : Gravel Wearing Course (2.5m)
Arterial or Feeder Road

SCALE : 1:50

DATE : May 2017

DRAWING NUMBER

SD05

GENERAL NOTES:

1. All dimensions are in millimetres unless otherwise stated
2. Do not scale from drawing
3. Road reserved shall be 30m for Arterial and 20m for Urban and Feeder roads.
4. All gravel material shall be approved by engineer prior to delivery to site
5. Base course and sub base course shall be conformed with California Bearing Ratio (CBR) value.
6. Sub-base shall have a 4 day soaked CBR of not less than 50% at 98% Maximum Dry Density (MDD) and road base shall have a 4 day soaked CBR of not less than 80% at 98% of MDD. Subgrade CBR shall not be less than 8% CBR at 95% MDD.
7. Miter drain shall be provided at least 100m interval in both side of road

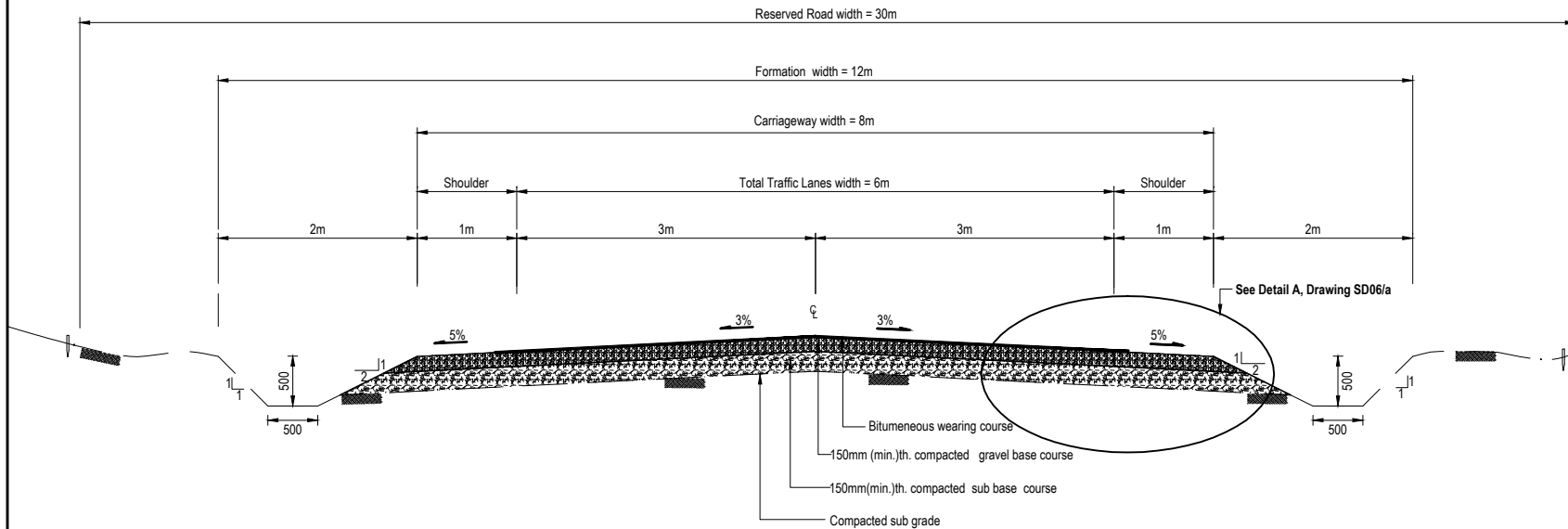

TYPICAL CROSS SECTION
(> 500 AADT)

			DESIGNED BY:	JH	 Public Works Department Private Mail Bag 9044 Tel: 22888 / 33460	PWD Standard Drawings		
			CAD BY:	HA		DRAWING TITLE : Bitumen Wearing Course (8m) Arterial Road		
			REVISED BY:	AP		SD06		
2.	REVIEW	08/16	APPROVED BY:	SN	SCALE : 1:50			
1.	ORIGINAL ISSUE	09/12						
No.	DESCRIPTION	DATE						

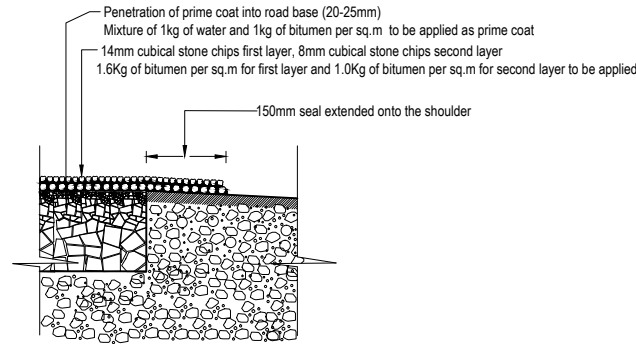

DETAIL B
 Scale 1:10

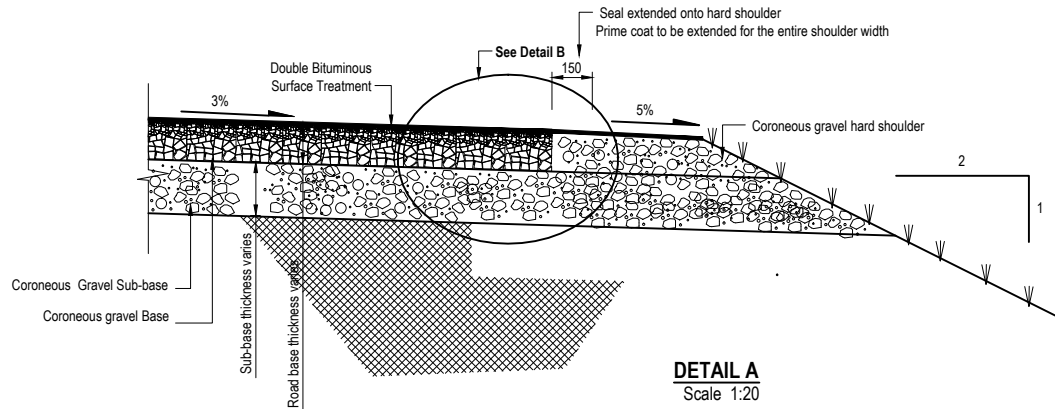

NOTES:

1. All dimensions are in millimetres unless otherwise stated
2. Do not scale from drawing
3. SS65 bitumen emulsion with 35% water shall be used and it should be approved by the Engineer prior using .
4. Emulsion prime coat shall be applied at a spread rate of 1.0kg per square metre.
5. Stone chips to be used for the surface treatment are to be cubical in shape, single sized, free of earth, dust and water before application. Flaky stone chips are to be rejected.
6. The first layer of surface treatment shall be rolled with a pneumatic wheeled roller without vibration and opened to construction traffic until the chips are firmly bedded into the bitumen layer. Following this the additional stone chips are to be brushed off the surface of the layer and the surface is to be cleaned by hand or mechanical brooming or with an air hose such that no dust, water or soil remains on the surface. The second layer is to be applied in the same manner as the first.
7. All shoulders shall be treated with prime coat with SS65 bitumen emulsion blinded with coarse sand.
8. Bitumen shall be sprayed at a normal temperature
9. Shoulders shall be constructed prior to the placement of road base or sub-base material using a pedestrian roller with vibration and trimming off excess material from the pavement area such that the shoulders will restrain the sub-base and road base layers during compaction
10. A gradation test is shall be carried on site and approved by the Engineer prior to approval being issued for the delivery of road base material
11. Sub-base shall have a 4 day soaked CBR of not less than 50% at 98% Maximum Dry Density (MDD) and road base shall have a 4 day soaked CBR of not less than 80% at 98% of MDD. Subgrade CBR shall not be less than 8% CBR at 95% MDD.
12. Coroneous material shall be used for subbase and shoulders is to be in strict accordance with the technical specifications for Coroneous base of sub base material.
13. Base and sub base thickness shall be specified in the schedule of work

			DESIGNED BY:		JH
			CAD BY:		HA
			REVISED BY:		AP
2.	REVIEW	08/16	APPROVED BY:		SN
1.	ORIGINAL ISSUE	09/12			
No.	DESCRIPTION	DATE			



Public Works Department

Private Mail Bag 9044

Tel: 22888 / 33460

PWD Standard Drawings

DRAWING TITLE : Bitumen Wearing Course (8m) - Details
 Arterial Road

SCALE : 1:50

DATE : May 2017

DRAWING NUMBER

SD06/a

GENERAL NOTES:

1. All dimensions are in millimetres unless otherwise stated
2. Do not scale from drawing
3. Road reserved shall be 30m for Arterial and 20m for Urban and Feeder roads.
4. All gravel material shall be approved by engineer prior to delivery to site
5. Base course and sub base course shall be conformed with California Bearing Ratio (CBR) value.
6. Sub-base shall have a 4 day soaked CBR of not less than 50% at 98% Maximum Dry Density (MDD) and road base shall have a 4 day soaked CBR of not less than 80% at 98% of MDD. Subgrade CBR shall not be less than 8% CBR at 95% MDD.
7. Miter drain shall be provided at least 100m interval in both side of road

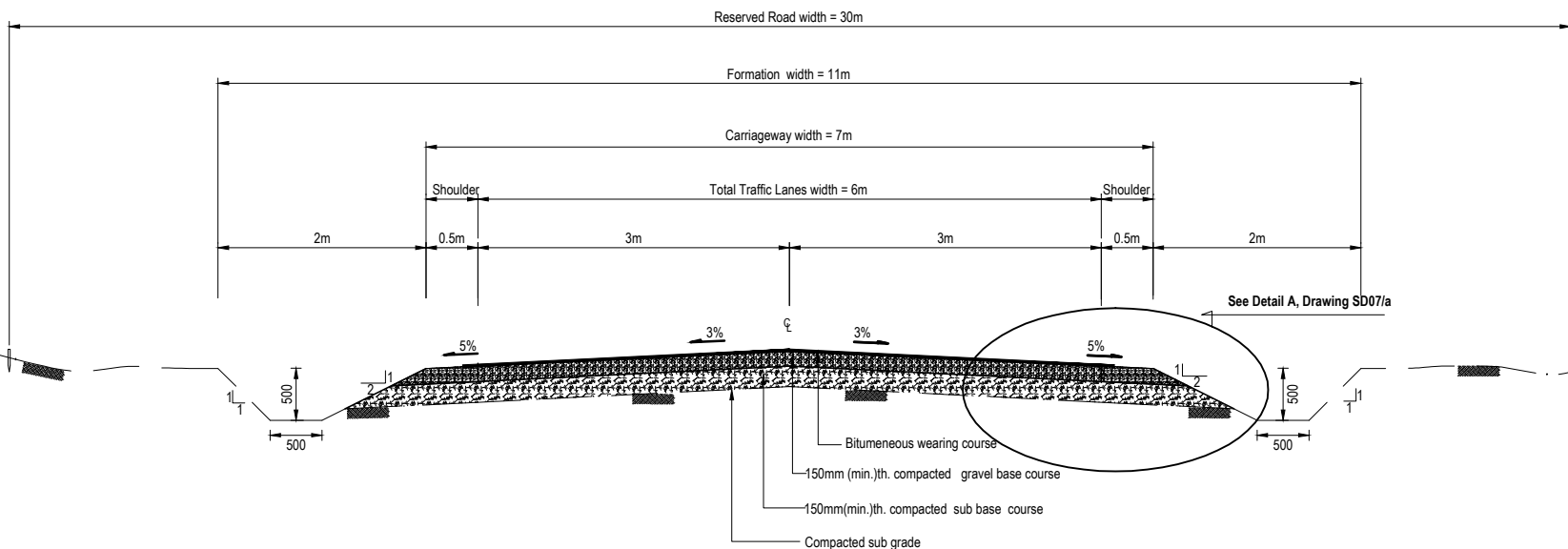

TYPICAL CROSS SECTION
(500-200 ADT)

			DESIGNED BY:	JH	 Public Works Department Private Mail Bag 9044 Tel: 22888 / 33460	PWD Standard Drawings		
			CAD BY:	HA		DRAWING TITLE : Bitumen Wearing Course (7m) Arterial Road	SD07	
			REVISED BY:	AP				
2.	REVIEW	08/16	APPROVED BY:	SN		SCALE : 1:50	DATE : May 2017	DRAWING NUMBER
1.	ORIGINAL ISSUE	09/12						
No.	DESCRIPTION	DATE						

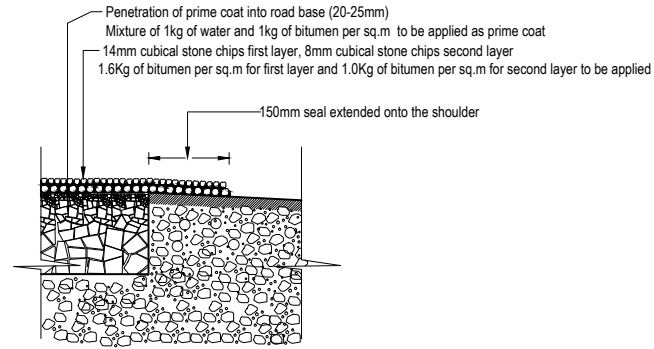

DETAIL B
 Scale 1:10

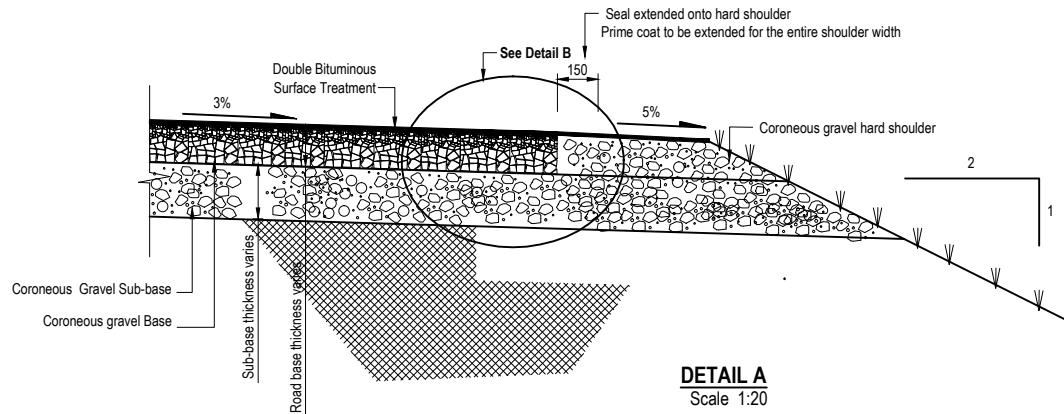

DETAIL A
 Scale 1:20

NOTES:

1. All dimensions are in millimetres unless otherwise stated
2. Do not scale from drawing
3. SS65 bitumen emulsion with 35% water shall be used and it should be approved by the Engineer prior using .
4. Emulsion prime coat shall be applied at a spread rate of 1.0kg per square metre.
5. Stone chips to be used for the surface treatment are to be cubical in shape, single sized, free of earth, dust and water before application. Flaky stone chips are to be rejected.
6. The first layer of surface treatment shall be rolled with a pneumatic wheeled roller without vibration and opened to construction traffic until the chips are firmly bedded into the bitumen layer. Following this the additional stone chips are to be brushed off the surface of the layer and the surface is to be cleaned by hand or mechanical brooming or with an air hose such that no dust, water or soil remains on the surface. The second layer is to be applied in the same manner as the first.
7. All shoulders shall be treated with prime coat with SS65 bitumen emulsion blinded with coarse sand.
8. Bitumen shall be sprayed at a normal temperature
9. Shoulders shall be constructed prior to the placement of road base or sub-base material using a pedestrian roller with vibration and trimming off excess material from the pavement area such that the shoulders will restrain the sub-base and road base layers during compaction
10. A gradation test is shall be carried on site and approved by the Engineer prior to approval being issued for the delivery of road base material
11. Sub-base shall have a 4 day soaked CBR of not less than 50% at 98% Maximum Dry Density (MDD) and road base shall have a 4 day soaked CBR of not less than 80% at 98% of MDD. Subgrade CBR shall not be less than 8% CBR at 95% MDD.
12. Coroneous material shall be used for subbase and shoulders is to be in strict accordance with the technical specifications for Coroneous base of sub base material.
13. Base and sub base thickness shall be specified in the schedule of work

			DESIGNED BY:	JH
			CAD BY:	HA
			REVISED BY:	AP
2.	REVIEW	08/16	APPROVED BY:	SN
1.	ORIGINAL ISSUE	09/12		
No.	DESCRIPTION	DATE		



Public Works Department

Private Mail Bag 9044

Tel: 22888 / 33460

PWD Standard Drawings

DRAWING TITLE : Bitumen Wearing Course (7m) - Details
 Arterial Road

SCALE : NTS

DATE : May 2017

DRAWING NUMBER

SD07/a

GENERAL NOTES:

1. All dimensions are in millimeters unless otherwise stated.
2. Do not scale from drawing.
3. Road reserved shall be 30m for Arterial and 20m for Urban and Feeder roads.
4. All gravel material shall be approved by engineer prior to delivery to site.
5. Base course and sub base course shall be conformed with California Bearing Ratio (CBR) value.
6. Sub-base shall have a 4 day soaked CBR of not less than 50% at 98% Maximum Dry Density (MDD) and road base shall have a 4 day soaked CBR of not less than 80% at 98% of MDD. Subgrade CBR shall not be less than 8% CBR at 95% MDD.
7. Miter drain shall be provided at least 100m interval in both side of road.

ROAD KERB

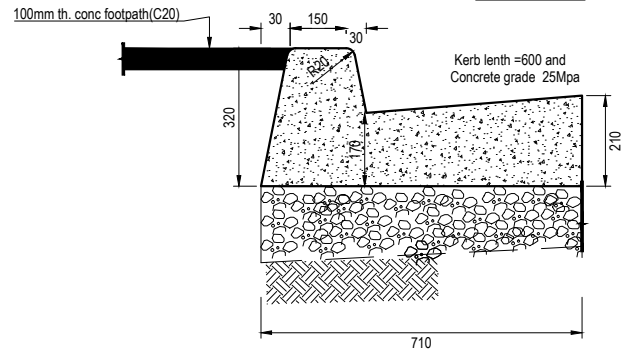

DETAIL X
Scale 1:20

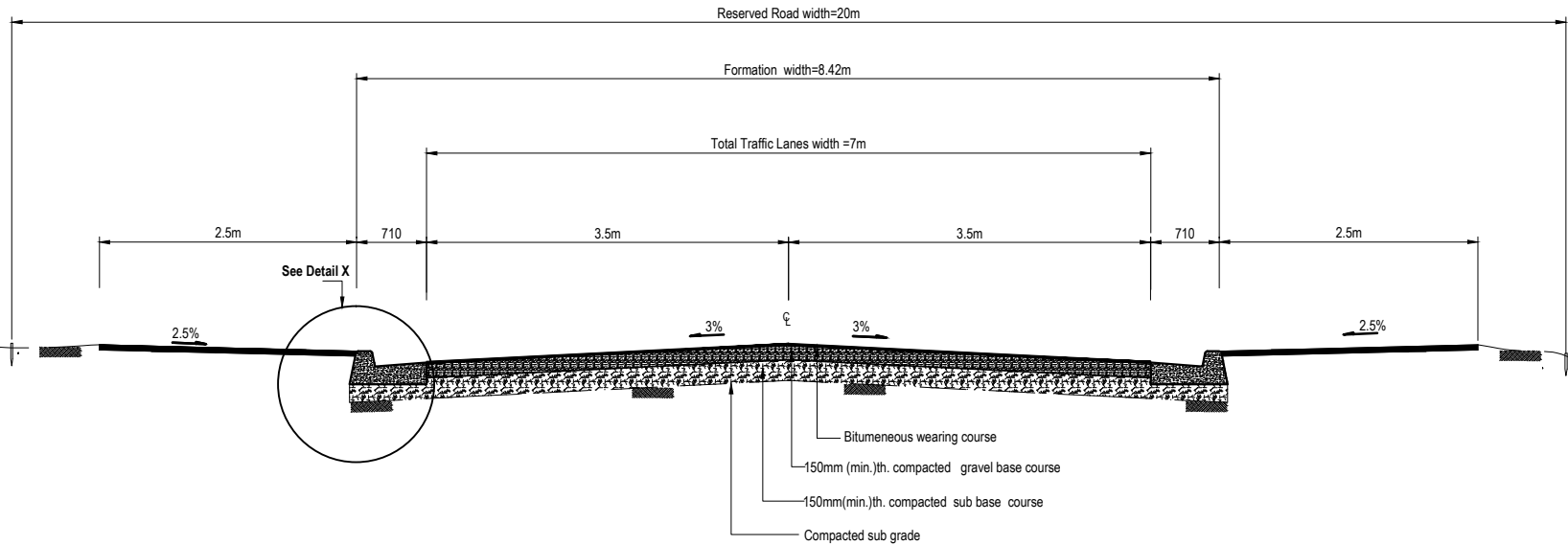

TYPICAL CROSS SECTION
1:50

			DESIGNED BY:	JH
			CAD BY:	HA
			REVISED BY:	AP
2.	REVIEW	08/16	APPROVED BY:	SN
1.	ORIGINAL ISSUE	09/12		
No.	DESCRIPTION	DATE		



Public Works Department

Private Mail Bag 9044

Tel: 22888 / 33460

PWD Standard Drawings

DRAWING TITLE : Bitumen Wearing Course (7m)
Urban Road with Kerb

SD08

SCALE : 1:50

DATE : May 2017

DRAWING NUMBER

GENERAL NOTES:

1. All dimensions are in millimeters unless otherwise stated.
2. Do not scale from drawing.
3. Road reserved shall be 30m for Arterial and 20m for Urban and Feeder roads.
4. All gravel material shall be approved by engineer prior to delivery to site.
5. Base course and sub base course shall be conformed with California Bearing Ratio (CBR) value.
6. Sub-base shall have a 4 day soaked CBR of not less than 50% at 98% Maximum Dry Density (MDD) and road base shall have a 4 day soaked CBR of not less than 80% at 98% of MDD. Subgrade CBR shall not be less than 8% CBR at 95% MDD.
7. Miter drain shall be provided at least 100m interval in both side of road.

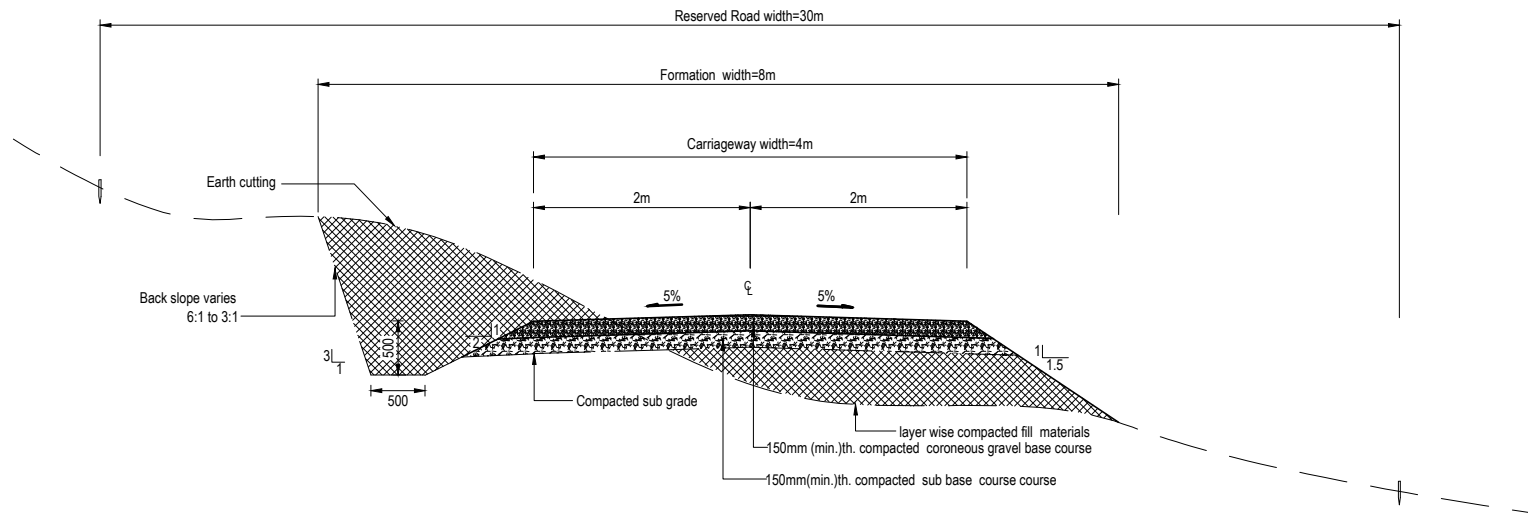

TYPICAL CROSS SECTION

			DESIGNED BY:	JH
			CAD BY:	HA
			REVISED BY:	AP
2.	REVIEW	08/16	APPROVED BY:	SN
1.	ORIGINAL ISSUE	09/12		
No.	DESCRIPTION	DATE		



Public Works Department

Private Mail Bag 9044

Tel: 22888 / 33460

PWD Standard Drawings

DRAWING TITLE :		Hill road (4m) Arterial Road
SCALE :	DATE :	DRAWING NUMBER
1:50	May 2017	

SD09

GENERAL NOTES:

1. All dimensions are in millimeters unless otherwise stated
2. Do not scale from drawing
3. Concrete shall comply with PWD Technical Specification for Road and Bridge Works.
4. Reinforcement shall comply with PWD Standard Technical Specification for Road and Bridge Works.
5. Curing of concrete shall comply with PWD Standard Technical Specification for Road and Bridge Works.
6. Concrete cover shall comply with PWD Standard Technical Specification for Road and Bridge Works.
7. Actual traffic lane width shall depend on traffic volumes and equal the traffic lane width as indicated in the typical cross sections

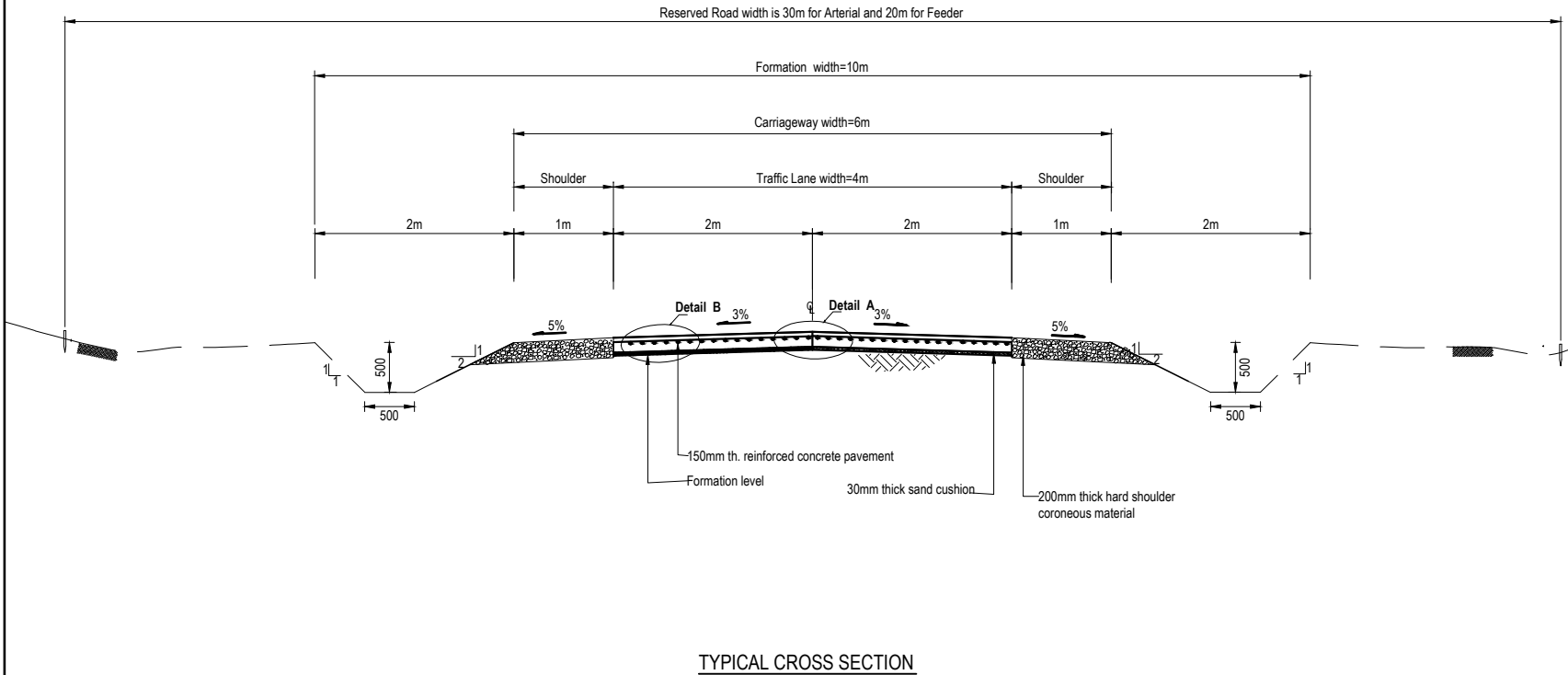

			DESIGNED BY:	JH
			CAD BY:	HA
			REVISED BY:	AP
2.	REVIEW	08/16	APPROVED BY:	SN
1.	ORIGINAL ISSUE	09/12		
No.	DESCRIPTION	DATE		



Public Works Department

Private Mail Bag 9044

Tel: 22888 / 33460

PWD Standard Drawings

DRAWING TITLE : Concrete Pavement

SD10

SCALE : 1:50

DATE : May 2107

DRAWING NUMBER

GENERAL NOTES:

1. All dimensions are in millimeters unless otherwise stated
2. Do not scale from drawing
3. Concrete shall comply with PWD Standard Technical Specification for Road and Bridge Works.
4. Reinforcement shall comply with PWD Standard Technical Specification for Road and Bridge Works.
5. Curing of concrete shall comply with PWD Standard Technical Specification for Road and Bridge Works.
6. Concrete cover shall comply with PWD Standard Technical Specification for Road and Bridge Works.

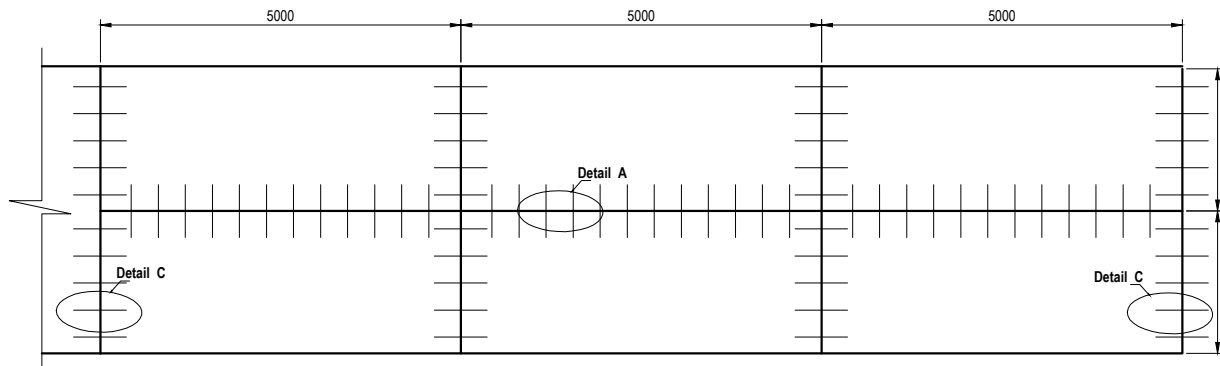
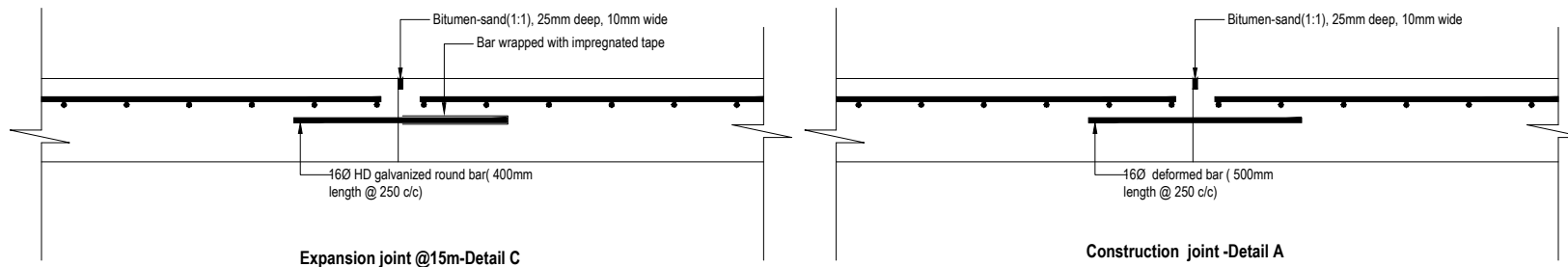
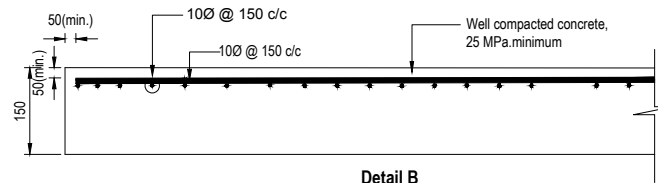

Plan of concrete pavement with dowel details

			DESIGNED BY:	JH
			CAD BY:	HA
			REVISED BY:	AP
2.	REVIEW	08/16	APPROVED BY:	SN
1.	ORIGINAL ISSUE	09/12		
No.	DESCRIPTION	DATE		



Public Works Department

Private Mail Bag 9044

Tel: 22888 / 33460

PWD Standard Drawings

DRAWING TITLE : Concrete Pavement - Details

SCALE : 1:50

DATE : May 2017

DRAWING NUMBER

SD10/a

GENERAL NOTES:

1. All dimensions are in millimeters unless otherwise stated
2. Do not scale from drawing
3. Concrete shall comply with PWD Standard Technical Specification for Road and Bridge Works.
4. Reinforcement shall comply with PWD Standard Technical Specification for Road and Bridge Works.
5. Curing of concrete shall comply with PWD Standard Technical Specification for Road and Bridge Works.
6. Concrete cover shall comply with PWD Standard Technical Specification for Road and Bridge Works.
7. This typical cross section shall be used only where traffic volumes are less than 50 VPD

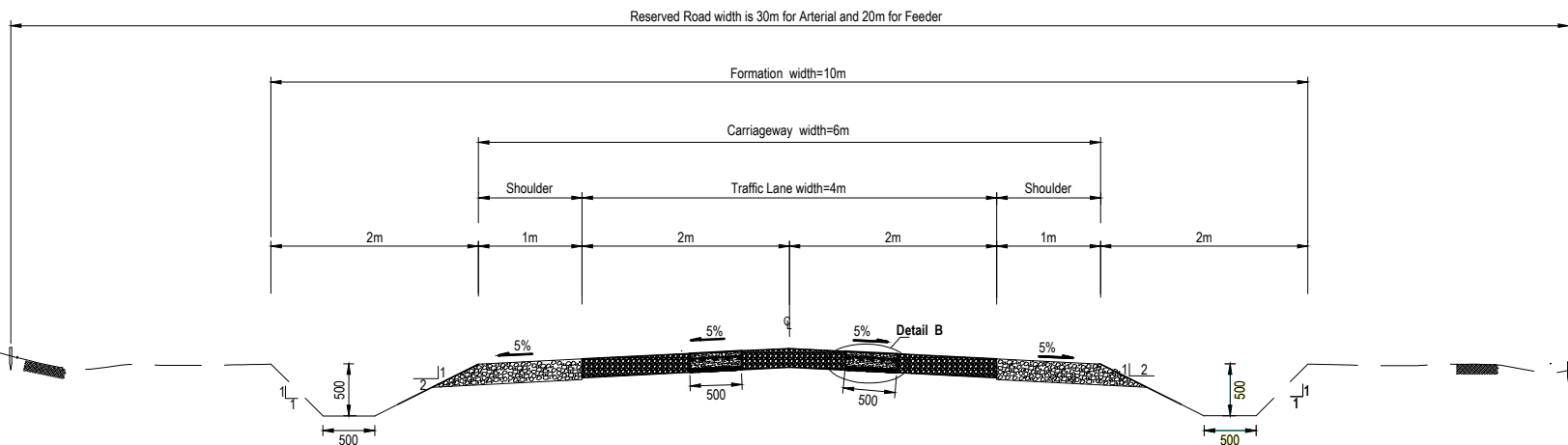

TYPICAL CROSS SECTION

			DESIGNED BY:	JH
			CAD BY:	HA
			REVISED BY:	AP
2.	REVIEW	08/16	APPROVED BY:	SN
1.	ORIGINAL ISSUE	09/12		
No.	DESCRIPTION	DATE		



Public Works Department

Private Mail Bag 9044

Tel: 22888 / 33460

PWD Standard Drawings

DRAWING TITLE : Strip Concrete Pavement

SCALE : 1:50

DATE : May 2017

DRAWING NUMBER

SD11

GENERAL NOTES:

1. All dimensions are in millimeters unless otherwise stated
2. Do not scale from drawing
3. Concrete shall comply with PWD Standard Technical Specification for Road and Bridge Works.
4. Reinforcement shall comply with PWD Standard Technical Specification for Road and Bridge Works.
5. Curing of concrete shall comply with PWD Standard Technical Specification for Road and Bridge Works.
6. Concrete cover shall comply with PWD Standard Technical Specification for Road and Bridge Works.

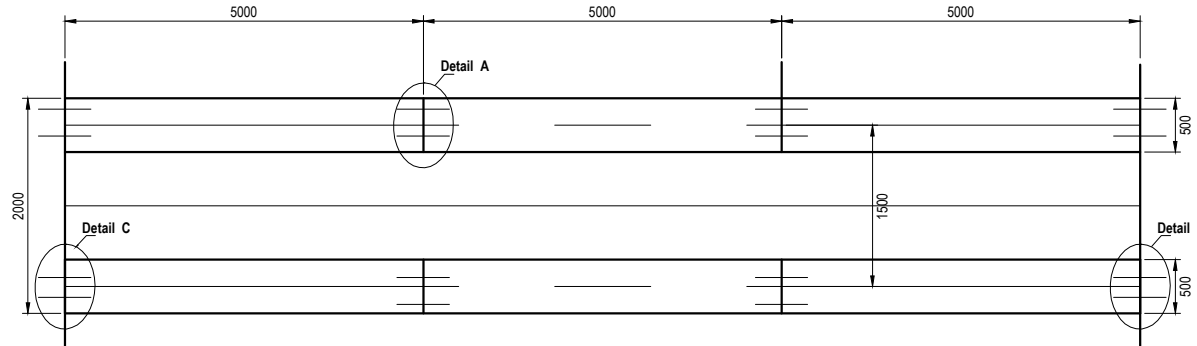
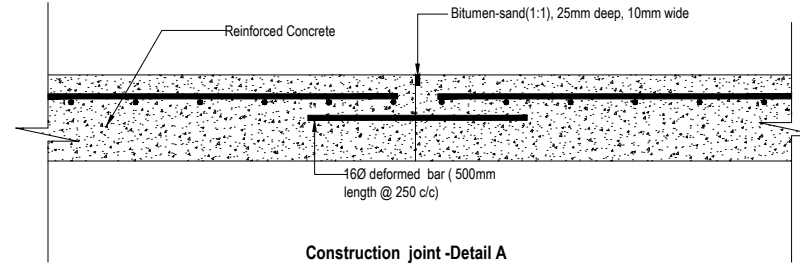
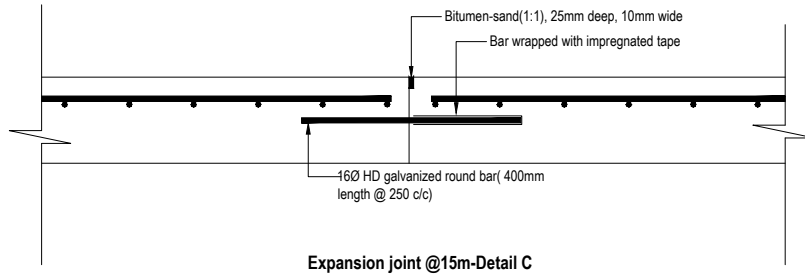
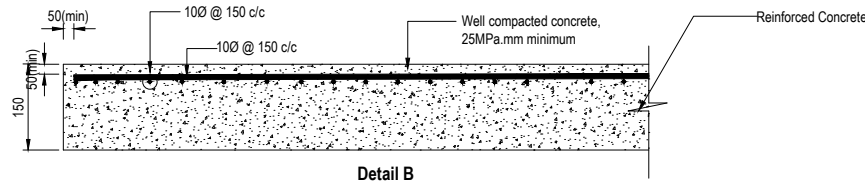

Plan of concrete strip with dowel details

			DESIGNED BY:		JH
			CAD BY:		HA
			REVISED BY:		AP
2.	REVIEW	08/16	APPROVED BY:		SN
1.	ORIGINAL ISSUE	09/12			
No.	DESCRIPTION	DATE			



Public Works Department

Private Mail Bag 9044

Tel: 22888 / 33460

PWD Standard Drawings

DRAWING TITLE : Strip Concrete Pavement - Details

SCALE : 1:50

DATE : May 2017

DRAWING NUMBER

SD11/a

- NOTES:**
1. All dimensions are in millimeter unless otherwise stated.
 2. Do not scale from drawing.
 3. Material shall comply with PWD Standard Technical Specification for Road and Bridge Works.
 4. Compaction shall comply with PWD Standard Technical Specification for Road and Bridge Works.
 5. Coronous material shall comply with PWD Standard Technical Specification for Road and Bridge Works.
 6. Actual traffic lane width shall depend on the traffic volumes and equal the traffic lane width as indicated in the typical cross sections or drawings SD01 - SD05

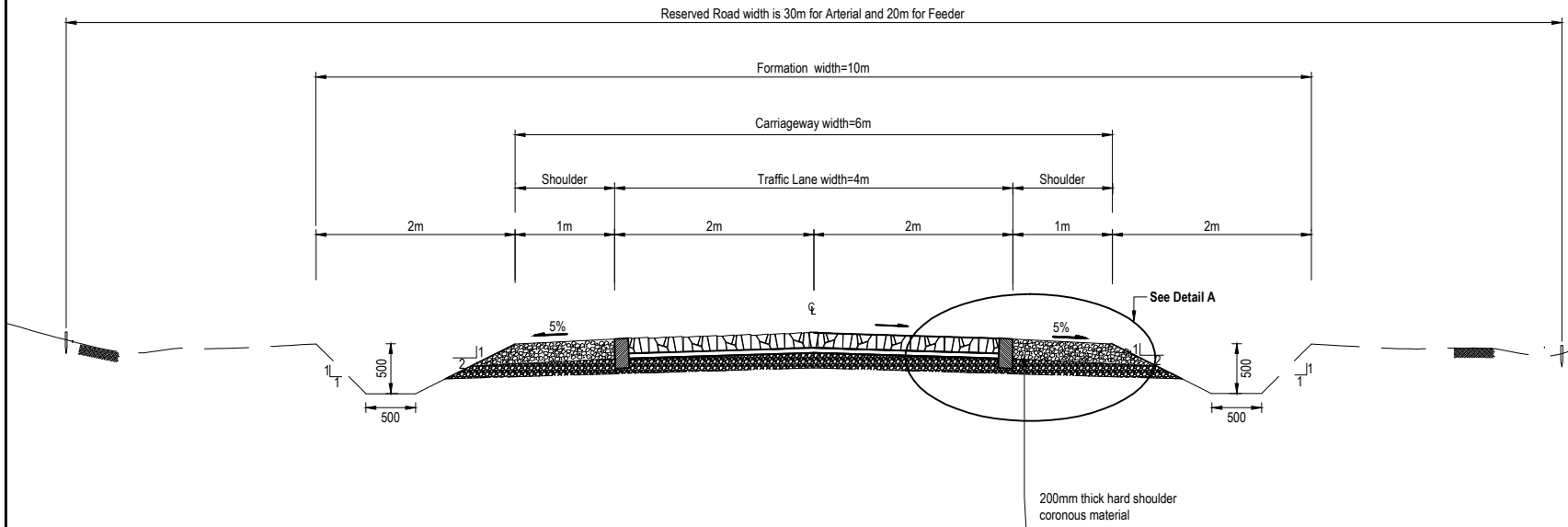

TYPICAL CROSS SECTION

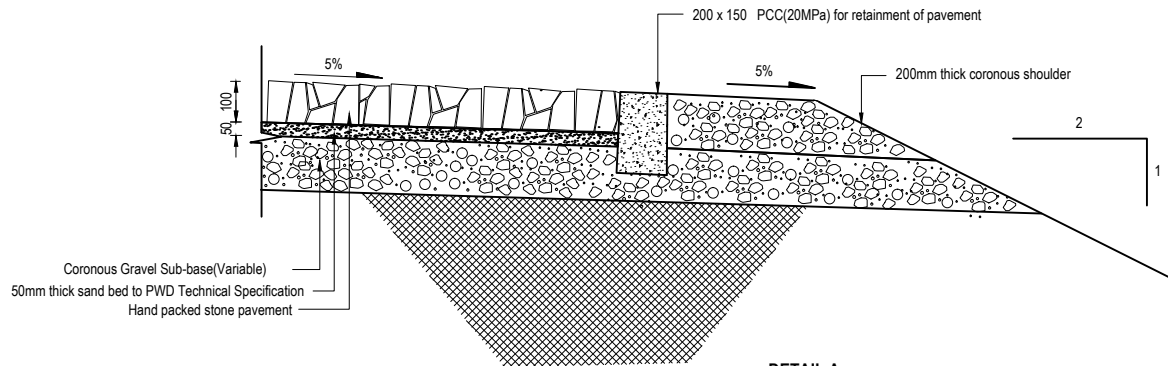

DETAIL A
Scale 1:20

			DESIGNED BY:	JH
			CAD BY:	HA
			REVISED BY:	AP
2.	REVIEW	08/16	APPROVED BY:	SN
1.	ORIGINAL ISSUE	09/12		
No.	DESCRIPTION	DATE		



Public Works Department

Private Mail Bag 9044

Tel: 22888 / 33460

PWD Standard Drawings

DRAWING TITLE : Stone Pavement

SD12

SCALE : 1:50

DATE : May 2017

DRAWING NUMBER

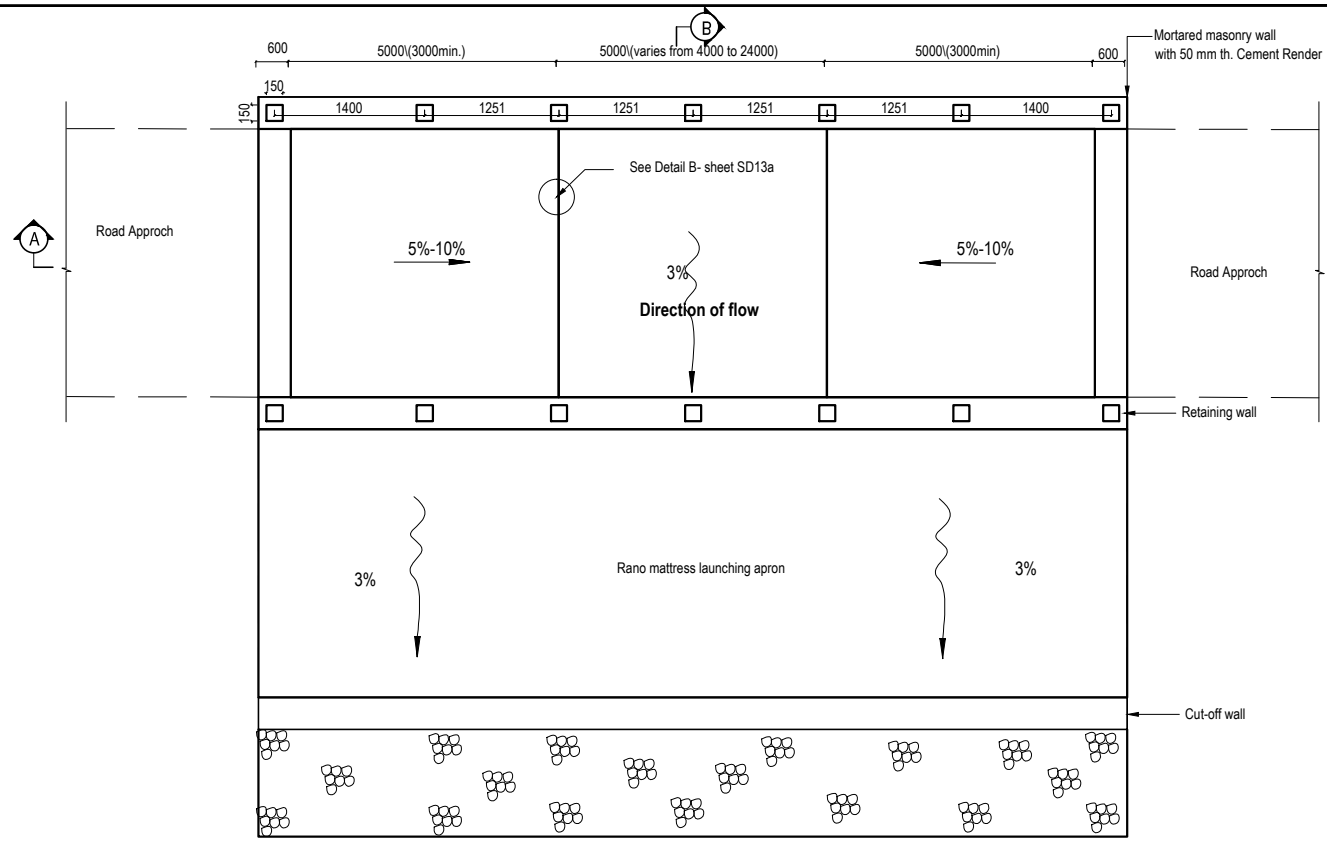

Plan View of Drift

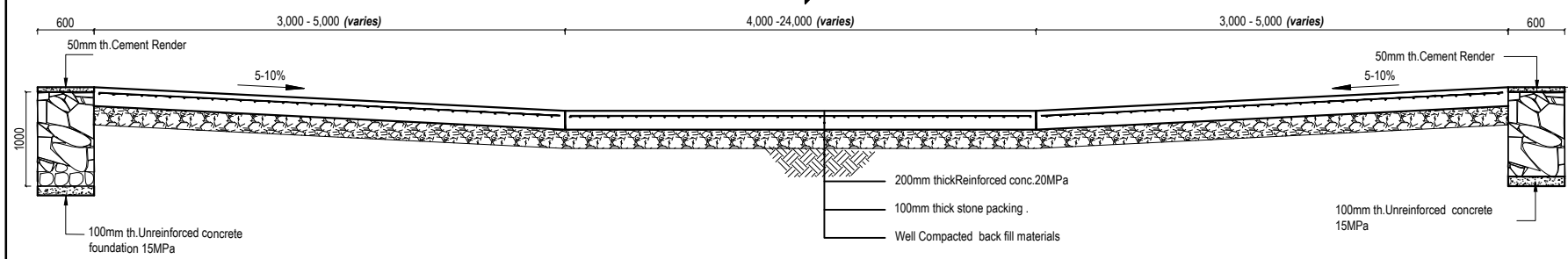

Section AA - Typical Drift

NOTES:

1. All dimensions in millimetres unless otherwise stated.
2. Material shall comply with PWD Standard Technical Specification for Road and Bridge Works.
3. All masonry work shall comply with PWD Standard Technical Specification for Road and Bridge Works.
4. Depth of mortared masonry retaining wall and cut-off wall to be designated by the Engineer taking account of site conditions.
5. Steel reinforcement shall comply with PWD Standard Technical Specification for Road and Bridge Works.
6. Concrete shall comply with PWD Standard Technical Specification for Road and Bridge Works.
7. Concrete curing shall comply with PWD Standard Technical Specification for Road and Bridge Works.
8. The central slab(s) of the wash shall be constructed with a crossfall not greater than 3%.
9. The approach slabs shall be constructed with a longitudinal grade not less than 5% and not greater than 10%.
10. See SD10/a for construction joints for RCC slab.
11. Down stream gabion protection will be detailed in the Schedule of Works where required.

			DESIGNED BY:	JH
			CAD BY:	HA
			REVISED BY:	AP
2.	REVIEW	08/16	APPROVED BY:	SN
1.	ORIGINAL ISSUE	09/12		
No.	DESCRIPTION	DATE		



Public Works Department
Private Mail Bag 9044

Tel: 22888 / 33460

PWD Standard Drawings		
DRAWING TITLE : Concrete Drift Plan & Section		
SCALE : 1:50	DATE : May 2017	DRAWING NUMBER
		SD13

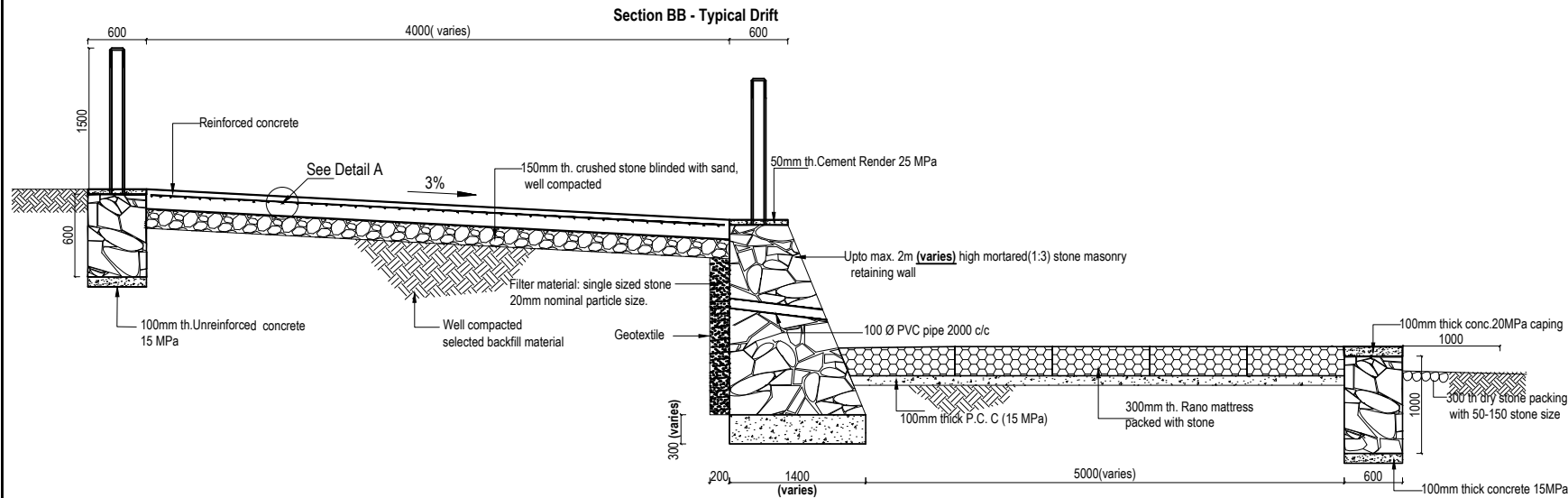

- NOTES:**
1. All dimensions in millimetres unless otherwise stated.
 2. Material shall comply with PWD Standard Technical Specification for Road and Bridge Works.
 3. All masonry work shall comply with PWD Standard Technical Specification for Road and Bridge Works.
 4. Depth of mortared masonry retaining wall and cut-off wall to be designated by the Engineer taking account of site conditions
 5. Steel reinforcement shall comply with PWD Standard Technical Specification for Road and Bridge Works.
 6. Concrete shall comply with PWD Standard Technical Specification for Road and Bridge Works.
 7. Concrete curing shall comply with PWD Standard Technical Specification for Road and Bridge Works.
 8. The central slab(s) of the wash shall be constructed with a crossfall not greater than 3%.
 9. The approach slabs shall be constructed with a longitudinal grade not less than 5% and not greater than 10%.
 10. See SD10/a for construction joints for RCC slab.
 11. Down stream gabion protection will be detailed in the Schedule of Works where required.

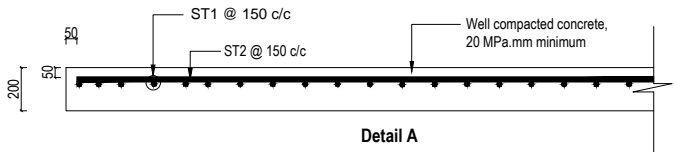

Bar Schedule (No. of bars presented are for single 5m x 4m slab)

Member	Bar Diameter	Shape Code	No. of Bars	Segment length		Total length - varies (metres)
				a	b	
Deck	10	ST1		3900		
Deck	10	ST2		4900		

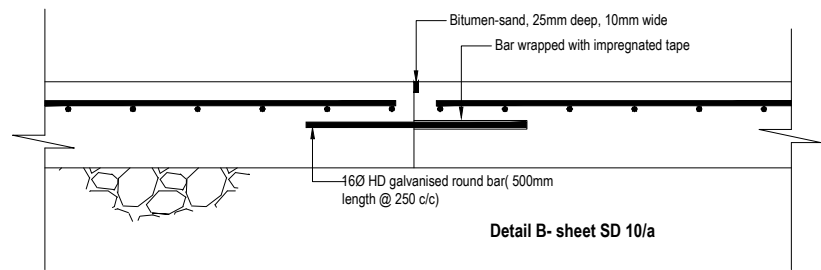

No.	DESCRIPTION	DATE
2.	REVIEW	08/16
1.	ORIGINAL ISSUE	09/12

DESIGNED BY:	JH
CAD BY:	HA
REVISED BY:	AP
APPROVED BY:	SN



Public Works Department
Private Mail Bag 9044

Tel: 22888 / 33460

PWD Standard Drawings

DRAWING TITLE : **Concrete Drift
Section BB & Details**

SCALE : 1:50 DATE : May 2017 DRAWING NUMBER

SD13/a

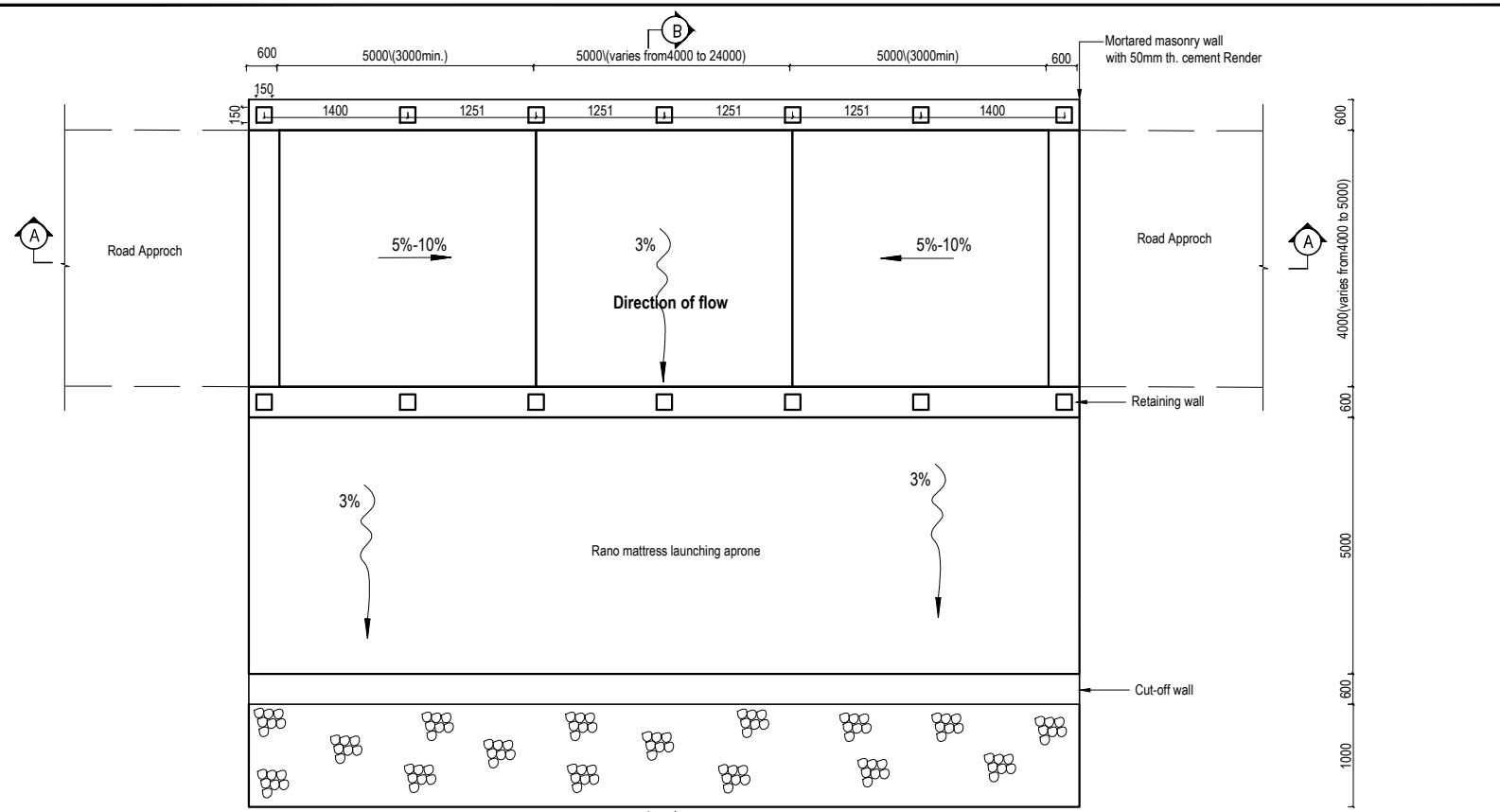

- NOTES:**
1. All dimensions in millimeters unless otherwise stated.
 2. Material shall comply with PWD Standard Technical Specification for Road and Bridge Works
 3. All masonry work shall comply with PWD Standard Technical Specification for Road and Bridge Works.
 4. Depth of mortared masonry retaining wall and cut-off wall to be designated by the Engineer taking account of site conditions.
 5. Concrete shall comply with PWD Standard Technical Specification Road and Bridge Works.
 6. The central leaf(s) of the wash shall be constructed with a crossfall not greater than 3%
 7. The approach leafs shall be constructed with longitudinal grade than 5% and not greater than 10%
 8. Down stream gabion protection will be detailed in the Schedule of Works where required.

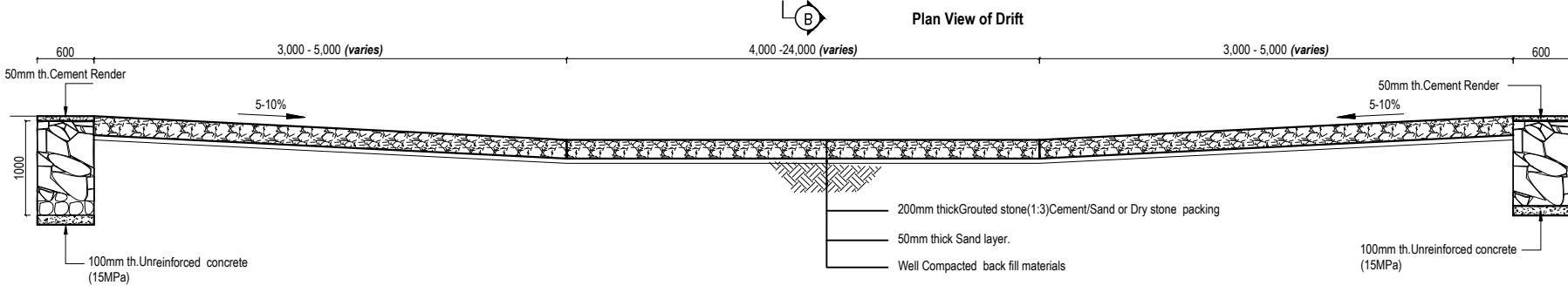

Section AA - Typical Drift

No.	DESCRIPTION	DATE
2.	REVIEW	08/16
1.	ORIGINAL ISSUE	09/12

DESIGNED BY:	JH
CAD BY:	HA
REVISED BY:	AP
APPROVED BY:	SN



Public Works Department
Private Mail Bag 9044
Tel: 22888 / 33460

PWD Standard Drawings		
DRAWING TITLE : Grouted Stone or Dry Stone packed Drift Plan & Section		
SCALE : 1:50	DATE : May 2017	DRAWING NUMBER
		SD14

Section BB - Typical Drift

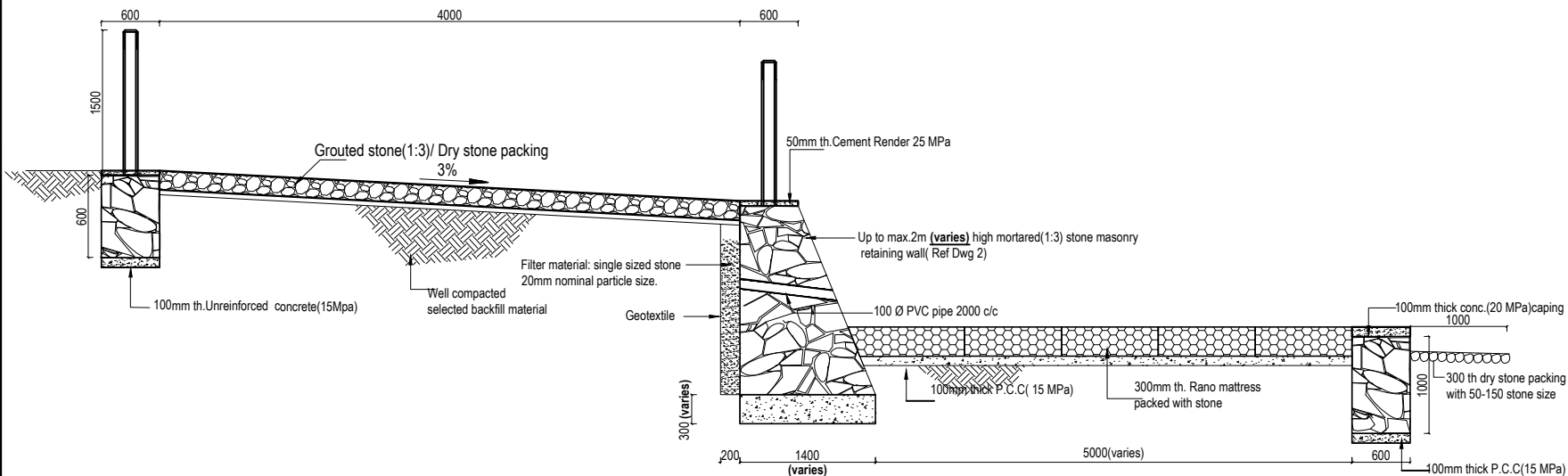

NOTES:

1. All dimensions in millimetres unless otherwise stated.
2. Material shall comply with PWD Standard Technical Specification for Road and Bridge Works.
3. All masonry work shall comply with PWD Standard Technical Specification for Road and Bridge Works.
4. Depth of mortared masonry retaining wall and cut-off wall to be designated by the Engineer taking account of site conditions.
5. Concrete shall comply with PWD Standard Technical Specification for Road and Bridge Works.
6. The central leaf(s) of the wash shall be constructed with a crossfall not greater than 3%
7. The approach leafs shall be constructed with longitudinal grade than 5% and not greater than 10%
8. Down stream gabion protection will be detailed in the Schedule of Works where required.

			DESIGNED BY:	JH
			CAD BY:	HA
			REVISED BY:	AP
2.	REVIEW	08/16		
1.	ORIGINAL ISSUE	09/12		
No.	DESCRIPTION	DATE	APPROVED BY:	SN



Public Works Department
Private Mail Bag 9044

Tel: 22888 / 33460

PWD Standard Drawings		
DRAWING TITLE : Grouted Stone or Dry Stone packed Drift Section BB		
SCALE : 1:50	DATE : May 2017	DRAWING NUMBER
		SD14/a

Typical Cross Section Gabion Retaining Wall & Land Protection

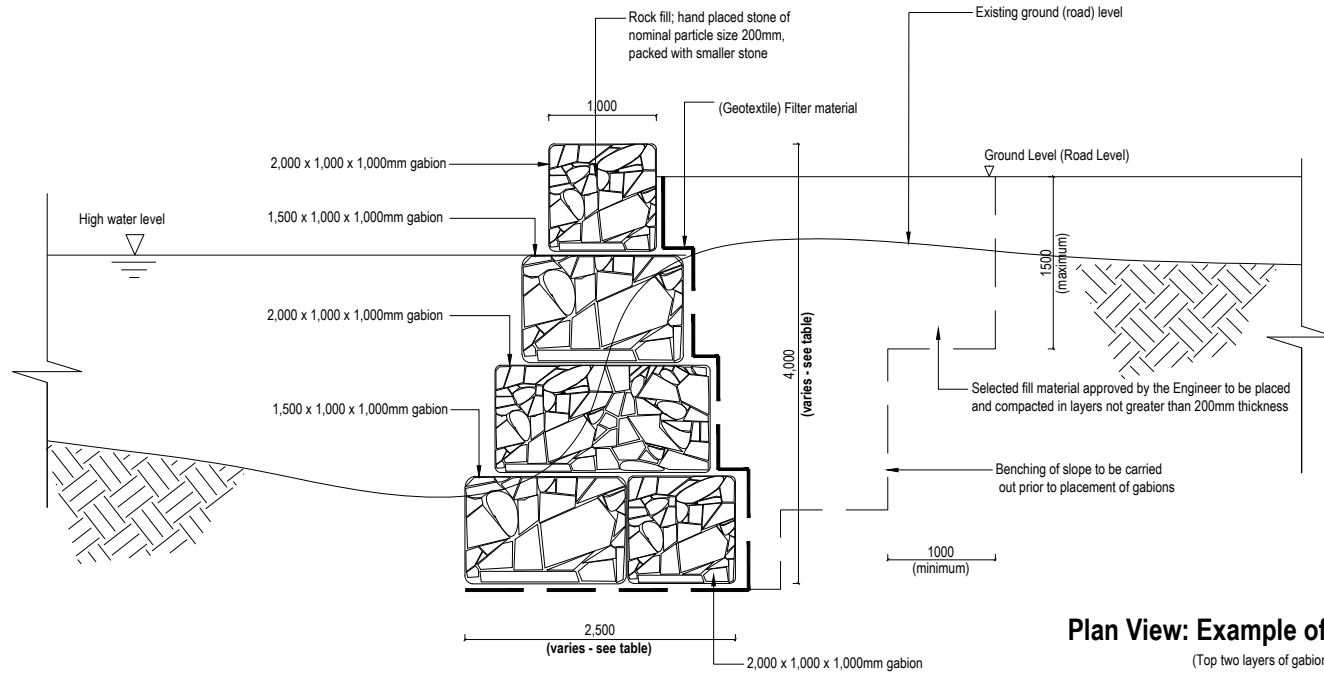

Plan View: Example of Gabion Placement

(Top two layers of gabions are shown only)

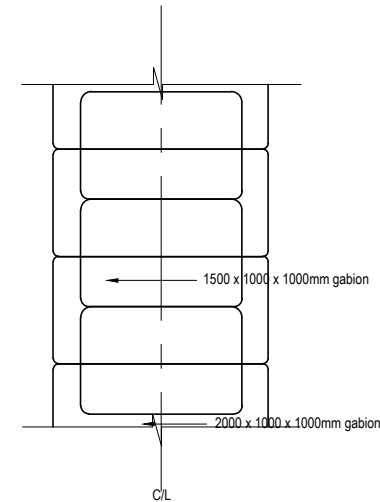

NOTES:

1. Do not scale from drawing.
2. All dimensions in millimetres unless otherwise stated.
3. Material shall comply with PWD Standard Technical Specification for Road and Bridge Works.
4. Back fill material shall comply with PWD Standard Technical Specification for Road and Bridge Works.
5. Earthwork excavation shall comply with PWD Standard Technical Specification for Road and Bridge Works.

Retaining Wall Height, Base Width & Ground Pressure

Wall Height (m)	2	3	4	6	8	10	12
Base Width (m)	1.5	2	2.5	3.5	4.5	5.5	6.5
Ground Pressure (kPa)	20	70	90	120	150	190	230

DESIGNED BY:		JH
CAD BY:		HA
REVISED BY:		AP
APPROVED BY:		SN
2.	REVIEW	08/16
1.	ORIGINAL ISSUE	09/12
No.	DESCRIPTION	DATE



Public Works Department

Private Mail Bag 9044

Tel: 22888 / 33460

PWD Standard Drawings

DRAWING TITLE: Gabion Retaining Wall and Land Protection

SCALE: 1:50

DATE: May 2017

DRAWING NUMBER

SD15

Typical Cross Section Mortared Random Rubble Masonry Retaining Wall

Retaining Wall Height, Base Width & Ground Pressure

Wall Height (m)	2	3	4	6	8	10	12	15
Base Width(B) (m)	1.4	1.8	2.2	3.0	3.6	4.6	5.4	6.6
Ground Pressure (kPa)	4	6	8	12	16	20	25	31

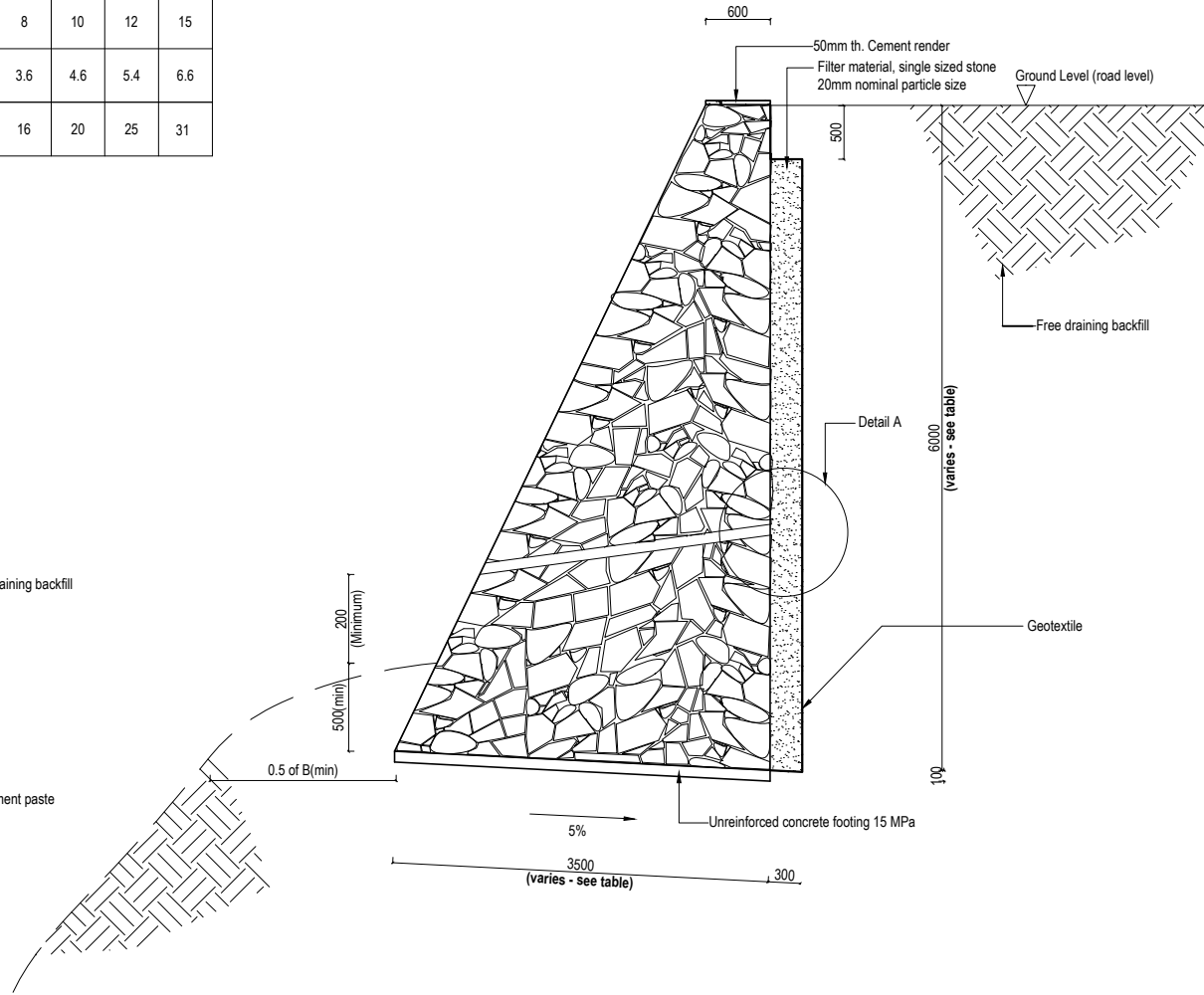
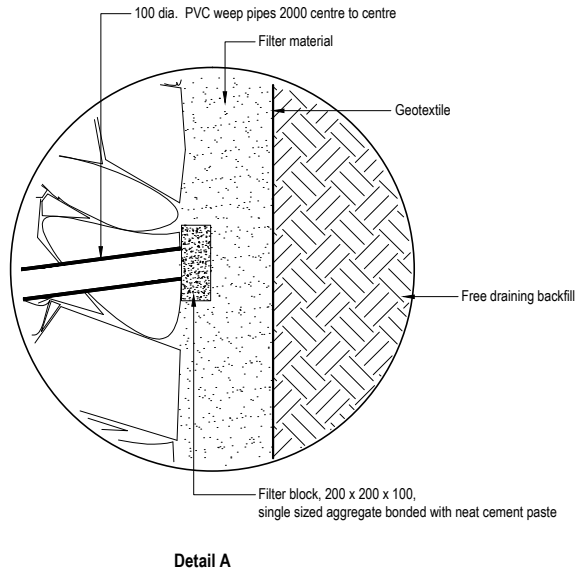

NOTES:

1. Do not scale from drawing
2. All dimensions in millimeters unless otherwise stated
3. Material shall comply with PWD Standard Technical Specification for Road and Bridge Works.
4. Concrete shall comply with PWD Standard Technical Specification for Road and Bridge Works.
5. Mortar mix shall comply with PWD Standard Technical Specification for Road and Bridge Works.
6. Earthwork excavation shall comply with PWD Standard Technical Specification for Road and Bridge Works.

			DESIGNED BY:	JH
			CAD BY:	HA
			REVISED BY:	AP
2.	REVIEW	08/16	APPROVED BY:	SN
1.	ORIGINAL ISSUE	09/12		
No.	DESCRIPTION	DATE		



Public Works Department

Private Mail Bag 9044

Tel: 22888 / 33460

PWD Standard Drawings

DRAWING TITLE : **Typical Mortared Random Rubble Masonry Retaining Wall**

SCALE : 1:50

DATE : May 2017

DRAWING NUMBER

SD16

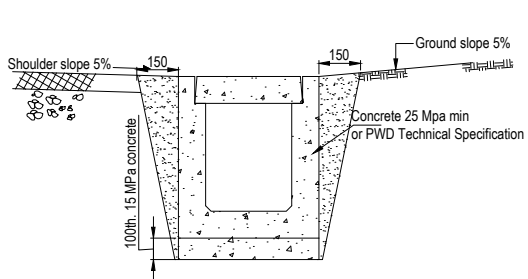

U-CONCRETE DRAIN: TYPE A

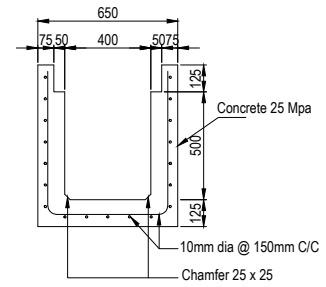

SECTION 1 - 1

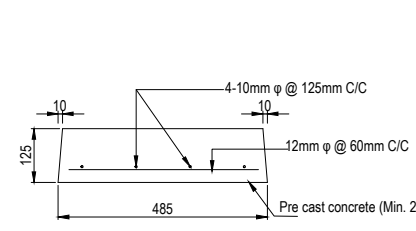

SECTION 2 - 2

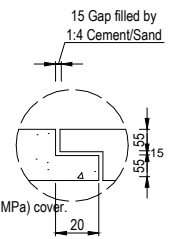

SECTION 3 - 3

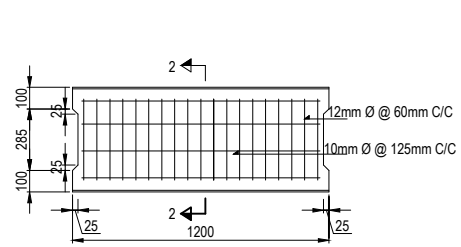

COVER SLAB-REINFORCEMENT

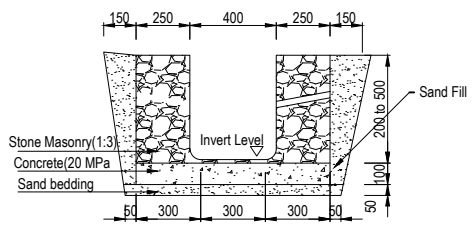

DETAILS SECTION OF STONE MASONRY SIDE DRAIN

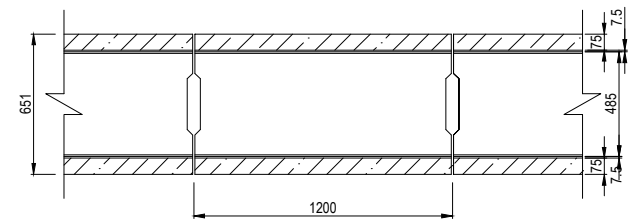

PLAN OF COVER SLAB

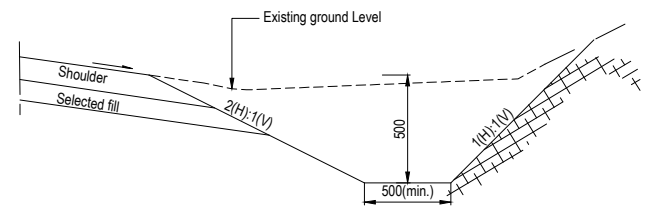

EARTHEN SIDE DRAIN

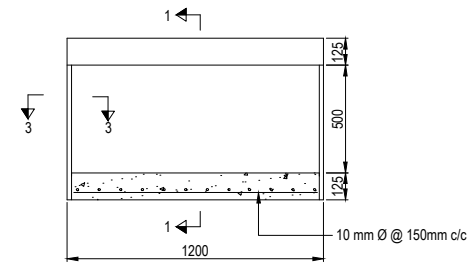

LONGITUDINAL SECTION

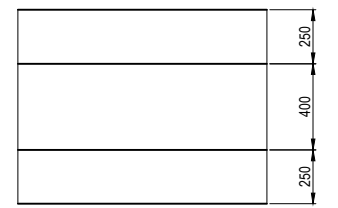

TOP PLAN OF STONE MASONRY DRAIN

- NOTES**
1. All dimensions are in millimeters unless otherwise specified
 2. Concrete shall comply with PWD Standard Technical Specification for Road and Bridge Works.
 3. Reinforcement shall comply with PWD Standard Technical Specification for Road and Bridge Works.
 4. Mortar shall comply with PWD Standard Technical Specification for Road and Bridge Works.
 5. Masonry side wall shall comply with PWD Standard Technical Specification for Road and Bridge Works.
 6. Concrete cover shall comply with PWD Standard Technical Specification for Road and Bridge Works.
 7. Stone shall comply with PWD Standard Technical Specification for Road and Bridge Works.

			DESIGNED BY:	JH
			CAD BY:	HA
			REVISED BY:	AP
2.	REVIEW	08/16	APPROVED BY:	SN
1.	ORIGINAL ISSUE	09/12		
No.	DESCRIPTION	DATE		



Public Works Department

Private Mail Bag 9044

Tel:22888 / 33460

PWD Standard Drawings

DRAWING TITLE: Typical drawings for drainage
(Lined drain /unlined drain)

SD17

SCALE: 1:25

DATE: May 2017

DRAWING NUMBER

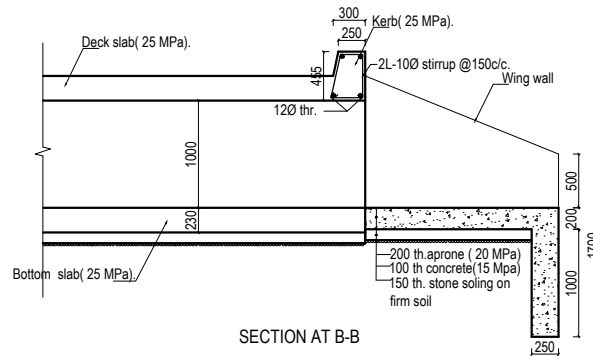
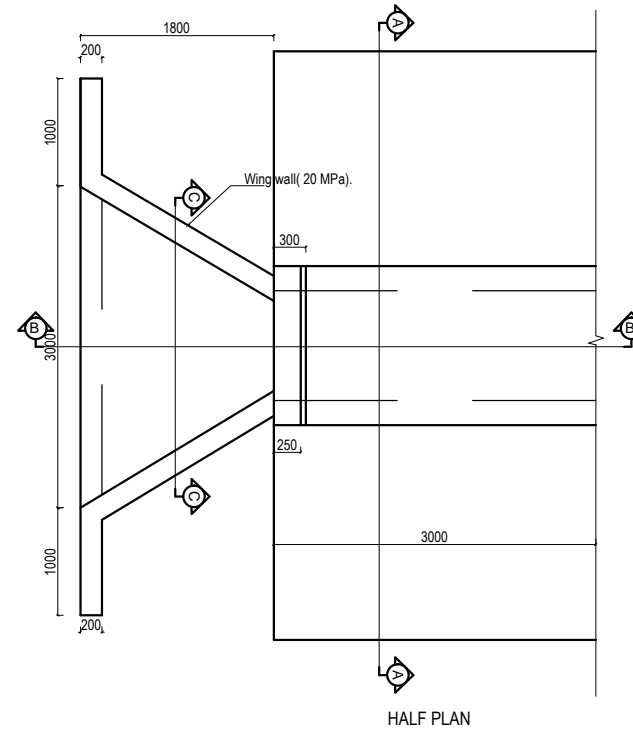
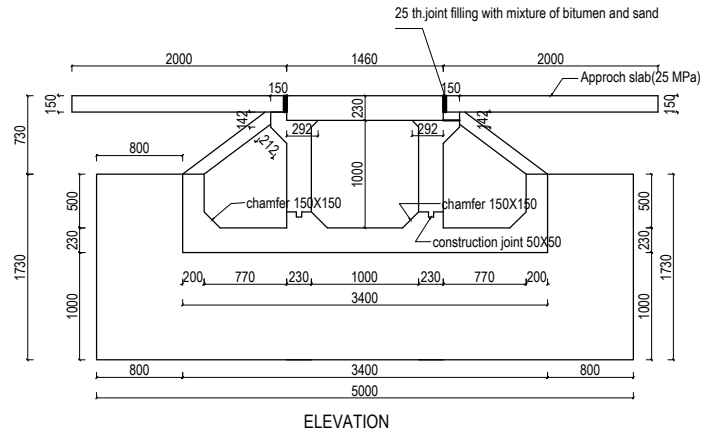

NOTES:

1. All dimensions are in millimetres unless otherwise stated
2. Do not scale from drawing
3. Concrete shall comply with PWD Standard Technical Specification for Road and Bridge works.
4. Reinforcement shall comply with PWD Standard Technical Specification for Road and Bridge Works
5. Curing of concrete shall comply with PWD Standard Technical Specification for Road and Bridge Works.
6. Concrete cover shall comply with PWD Standard Technical specification for Road and Bridge Works.

			DESIGNED BY:	JH
			CAD BY:	HA
			REVISED BY:	AP
2.	REVIEW	08/16	APPROVED BY:	SN
1.	ORIGINAL ISSUE	09/12		
No.	DESCRIPTION	DATE		



Public Works Department

Private Mail Bag 9044

Tel: 22888 / 33460

PWD Standard Drawings

DRAWING TITLE : **Box Culvert (1mX1m)**

SCALE : NTS

DATE : May 2017

DRAWING NUMBER

SD18

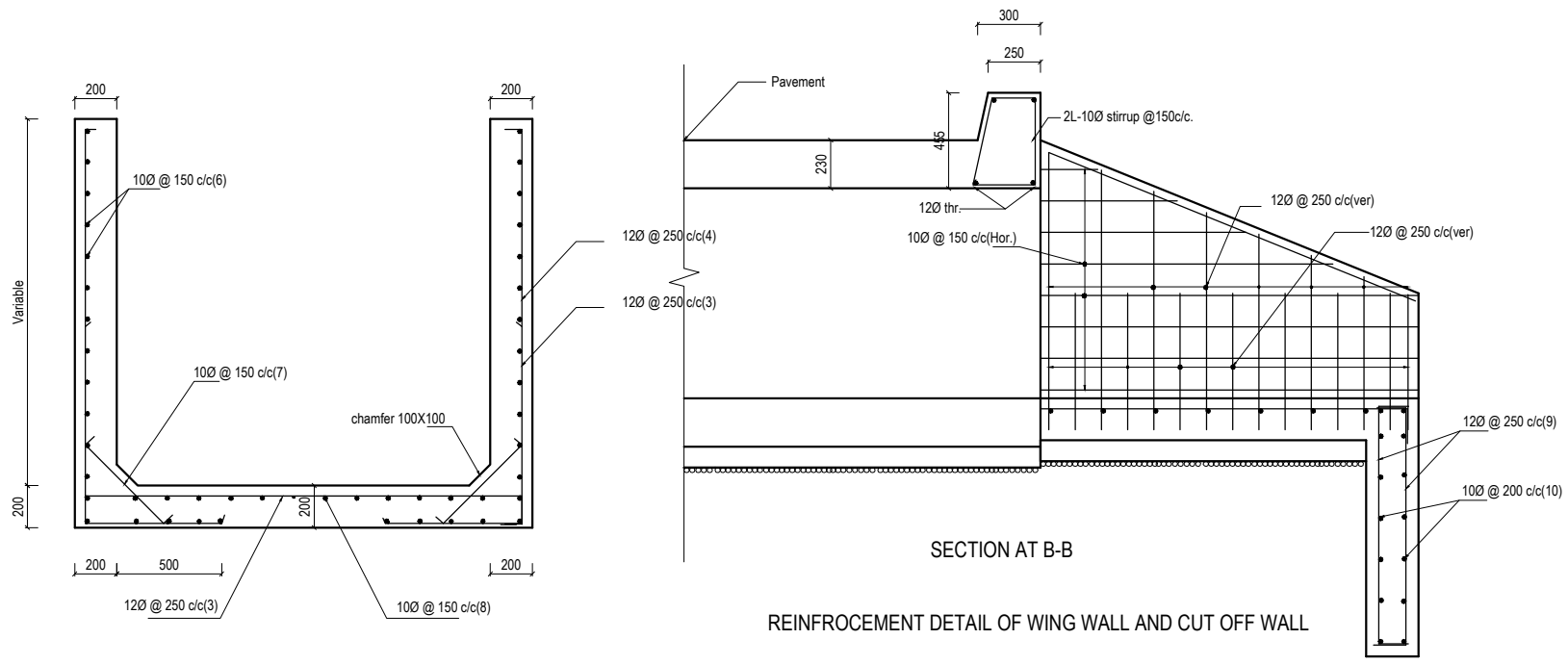

SECTION AT C-C
(REINFORCEMENT DETAIL)

SECTION AT B-B

REINFORCEMENT DETAIL OF WING WALL AND CUT OFF WALL

NOTES:

1. All dimensions are in millimetres unless otherwise stated
2. Do not scale from drawing
3. Concrete shall comply with PWD Standard Technical Specification for Road and Bridge Works .
4. Reinforcement shall comply with PWD Standard Technical Specification for Road and Bridge Works.
5. Curing of concrete shall comply with PWD Standard Technical Specification for Road and Bridge Works.
6. Concrete cover shall comply with PWD Standard Technical Specification for Road and Bridge Works.

			DESIGNED BY:	JH
			CAD BY:	HA
			REVISED BY:	AP
2.	REVIEW	08/16	APPROVED BY:	SN
1.	ORIGINAL ISSUE	09/12		
No.	DESCRIPTION	DATE		



Public Works Department

Private Mail Bag 9044

Tel: 22888 / 33460

PWD Standard Drawings

DRAWING TITLE : Box Culvert (1mx1m) Reinforcement Details 1

SCALE : 1 : 25

DATE : May 2017

DRAWING NUMBER

SD18/a

NOTES:

1. All dimensions are in millimetres unless otherwise stated
2. Do not scale from drawing
3. Concrete shall comply with PWD Standard Technical Specification for Road and Bridge Works .
4. Reinforcement shall comply with PWD Standard Technical Specification for Road and Bridge Works.
5. Curing of concrete shall comply with PWD Standard Technical Specification for Road and Bridge Works.
6. Concrete cover shall comply with PWD Standard Technical Specification for Road and Bridge Works.

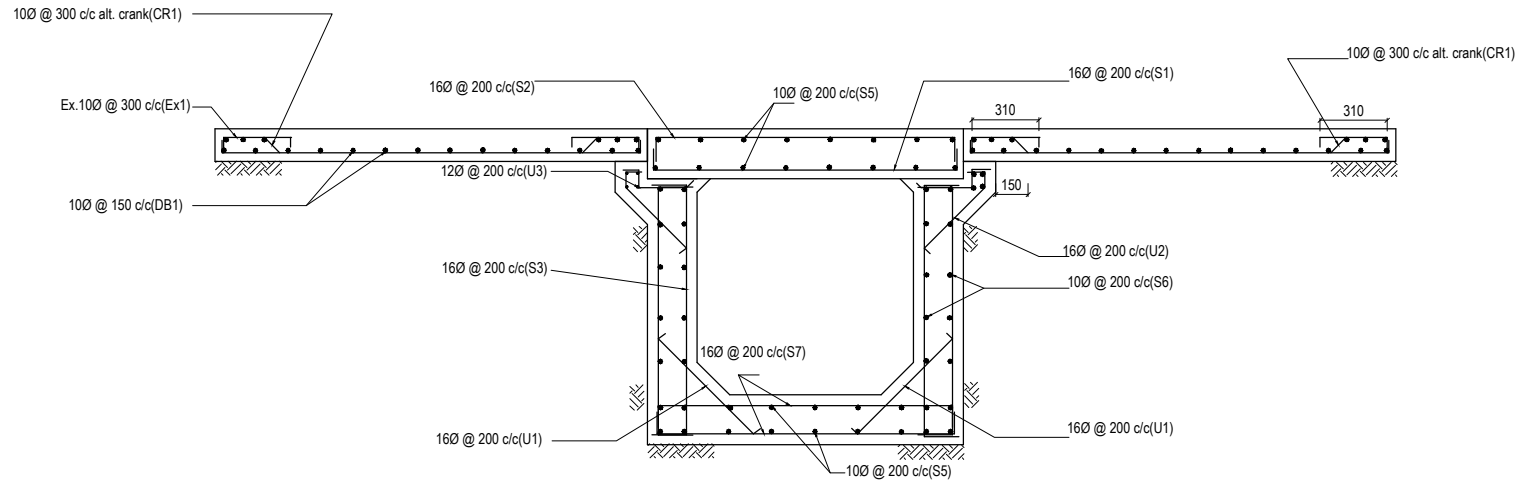

SECTION AT A-A(REINFORCEMENT DETAIL)

2.	REVIEW	08/16
1.	ORIGINAL ISSUE	09/12
No.	DESCRIPTION	DATE

DESIGNED BY:	JH
CAD BY:	HA
REVISED BY:	AP
APPROVED BY:	SN



Public Works Department
Private Mail Bag 9044
Tel:22888 / 33460

PWD Standard Drawings		
DRAWING TITLE :		Box Culvert (1mx1m) Reinforcement Details 2
SCALE : 1 : 25	DATE : May 2017	SD18/b
		DRAWING NUMBER

Bar Bending schedule for Box culvert(Bottom slab)

S.N.	Shape	Bar mark	Dia.	No.	Length (m)	Weight Kg/m	Total wt. (kg)
1.0		S7	16	31	1.664	1.58	81.50
2.0		S7	16	31	1.664	1.58	81.50
3.0		S5	10	9	6.11	0.62	34.1
4.0		S5	10	9	6.11	0.62	34.1
5.0		U1	16	62	0.941	1.58	92.18
	TOTAL						323.38

Bar Bending schedule for Box culvert(Deck slab)

S.N.	Shape	Bar mark	Dia.	No.	Length (m)	Weight Kg/m	Total wt. (kg)
1.0		S2	16	31	1.684	1.58	82.48
2.0		S1	16	41	1.684	1.58	109.09
3.0		S5	10	9	6.11	0.62	34.1
4.0		S5	10	9	6.11	0.62	34.1
	TOTAL						259.77

Bar Bending schedule for Box culvert(Wall))

S.N.	Shape	Bar mark	Dia.	No.	Length (m)	Weight Kg/m	Total wt. (kg)
1.0		S3	16	31	1.434	1.58	70.24
2.0		S3	16	31	1.434	1.58	70.24
3.0		S6	10	8	6.11	0.62	30.31
4.0		S6	10	12	6.11	0.62	45.46
5.0		U2	16	31	0.787	1.58	38.55
6.0		U3	12	31	0.497	0.89	13.7
	TOTAL						268.5
	FOR OTHER WALL						537.0

DESIGNED BY:	JH
CAD BY:	HA
REVISED BY:	AP
APPROVED BY:	SN
2. REVIEW	08/16
1. ORIGINAL ISSUE	09/12
No. DESCRIPTION	DATE



Public Works Department

Private Mail Bag 9044

Tel: 22888 / 33460

PWD Standard Drawings

DRAWING TITLE : Box Culvert (1mX1m)
Bar Bending Schedule 1

SCALE : 1:50

DATE : May 2017

DRAWING NUMBER

SD18/d

Bar Bending schedule for Box culvert(Approach slab)

S.N.	Shape	Bar mark	Dia.	No.	Length (m)	Weight Kg/m	Total wt. (kg)
1.0		CR1	10	21	2.157	0.62	28.1
2.0		CR1	10	21	2.157	0.62	28.1
3.0		DB1	10	2X3=6	6.11	0.62	22.73
4.0		DB1	10	15	6.11	0.62	56.82
5.0		EX1	10	2X21=42	0.941	0.62	24.5
6.0	TOTAL						160.25
	FOR TWO ,TOTAL						320.5

Bar Bending schedule for Box culvert(Wing wall)

S.N.	Shape	Bar mark	Dia.	No.	Length (m)	Weight Kg/m	Total wt (kg)
1.0		(4)	12	10	1.274	0.89	11.34
2.0		(3)	12	10	1.270	0.89	11.30
3.0		(6)	10	5	2.356	0.62	7.3
4.0		(6)	10	6	1.178	0.62	4.38
5.0		(7)	10	16	0.728	0.62	7.25
6.0		(6)	10	5	2.356	0.62	7.3
	TOTAL						48.87
	For four , total						195.48

NOTES:

- All dimensions are in millimeters unless otherwise specified
- Contractor is responsible for checking reinforcement quantity against the reinforcement detail drawings.

Bar Bending schedule for Box culvert(Kerb)

S.N.	Shape	Bar mark	Dia.	No.	Length (m)	Weight Kg/m	Total wt. (kg)
1.0			12	4	1.588	0.89	5.65
2.0			10	11	1.640	0.62	11.18
3.0	TOTAL						16.84
	For two side TOTAL						33.67

GRAND TOTAL 1872.32kg

Bar Bending schedule for Box culvert(Cut off wall and apron)

S.N.	Shape	Bar mark	Dia.	No.	Length (m)	Weight Kg/m	Total wt (kg)
1.0		(9)	12	21	1.128	0.89	21.1
2.0		(9)	12	21	1.128	0.89	21.1
3.0		(10)	10	5	5.096	0.62	15.78
4.0		(10)	10	5	5.096	0.62	15.78
5.0		(3)	12	8	1.88	0.89	13.4
6.0		(8)	10	12	1.890	0.62	14.1
	TOTAL						101.26
	For Two , total						202.52

DESIGNED BY:	JH
CAD BY:	HA
REVISD BY:	AP
APPROVED BY:	SN
2. REVIEW	08/16
1. ORIGINAL ISSUE	09/12
No. DESCRIPTION	DATE



Public Works Department

Private Mail Bag 9044

Tel: 22888 / 33460

PWD Standard Drawings

DRAWING TITLE : Box Culvert (1mX1m)
Bar Bending Schedule 2

SCALE : 1:50

DATE : May 2017

DRAWING NUMBER

SD18/e

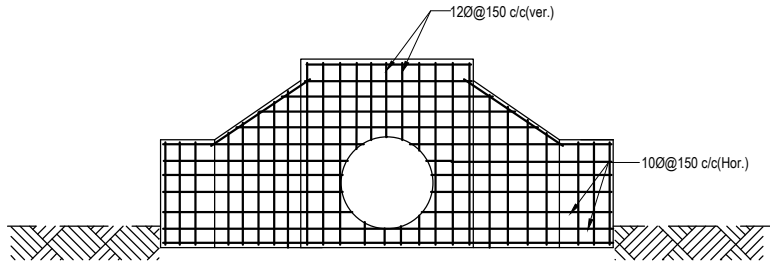

WINGWALL REINFORCEMENT DETAILS

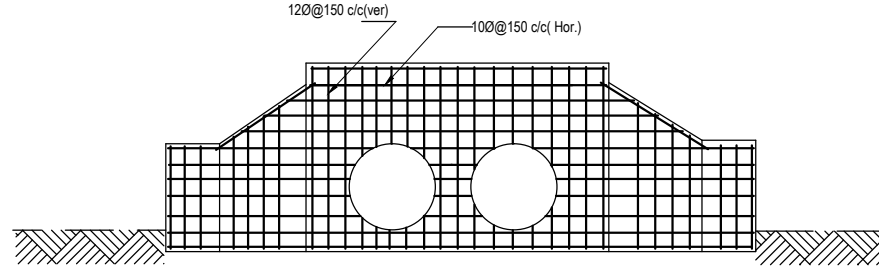

WINGWALL REINFORCEMENT DETAILS

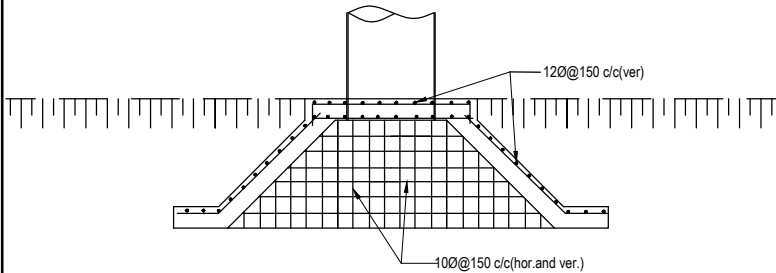

HEAD WALL WING WALL & APRON REINFORCEMENT DETAILS

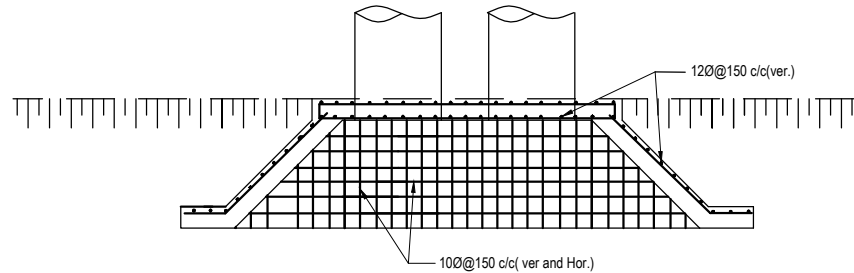

HEAD WALL, WING WALL & APRON REINFORCEMENT DETAILS

- NOTES:**
1. All dimensions are in millimetres unless otherwise stated
 2. Do not scale from drawing
 3. Minimum pipe length shall be 1,000mm.
 4. Concrete shall comply with PWD Standard Technical Specification for Road and Bridge Works.
 5. Reinforcement shall comply with PWD Standard Technical Specification for Road and Bridge Works.
 6. Curing of concrete shall comply with PWD Standard Technical Specification for Road and Bridge Works.
 7. Corrugated steel Pipe shall comply with PWD Standard Technical Specification for Road and Bridge Works
 8. Concrete cover shall comply with PWD Standard Technical Specification for Road and Bridge Works.
 9. Masonry wall shall comply with PWD Standard Technical Specification for Road and Bridge Works.
 10. Stone shall comply with PWD Standard Technical Specification for Road and Bridge Works.

			DESIGNED BY:	JH
			CAD BY:	HA
			REVISED BY:	AP
2.	REVIEW	08/16	APPROVED BY:	SN
1.	ORIGINAL ISSUE	09/12		
No.	DESCRIPTION	DATE		



Public Works Department

Private Mail Bag 9044

Tel: 22888 / 33460

PWD Standard Drawings

DRAWING TITLE: **Typical Drawings for 1,050 mm Pipe Culvert Single & Double, Reinforcement Details**

SD19

SCALE: NTS

DATE: May 2017

DRAWING NUMBER

- NOTES:**
1. All dimensions are in millimetres unless otherwise stated
 2. Do not scale from drawing
 3. Minimum pipe length shall be 1,000mm.
 4. Concrete shall comply with PWD Standard Technical Specification for Road and Bridge Works.
 5. Reinforcement shall comply with PWD Standard Technical Specification for Road and Bridge Works.
 6. Curing of concrete shall comply with PWD Standard Technical Specification for Road and Bridge Works.
 7. Corrugated steel Pipe shall comply with PWD Standard Technical Specification for Road and Bridge Works
 8. Concrete cover shall comply with PWD Standard Technical Specification for Road and Bridge Works.
 9. Masonry wall shall comply with PWD Standard Technical Specification for Road and Bridge Works.
 10. Stone shall comply with with PWD Standard Technical Specification for Road and Bridge Works.

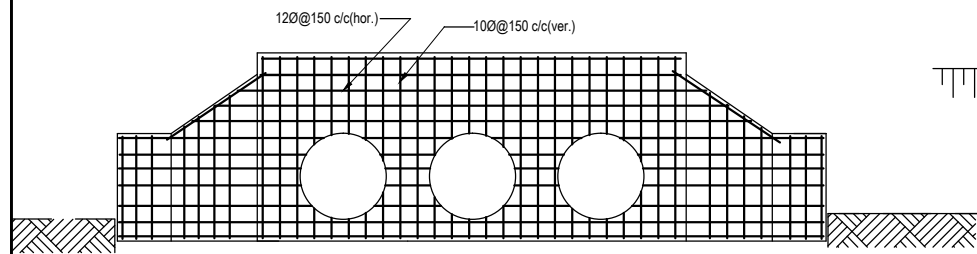

WINGWALL REINFORCEMENT DETAILS

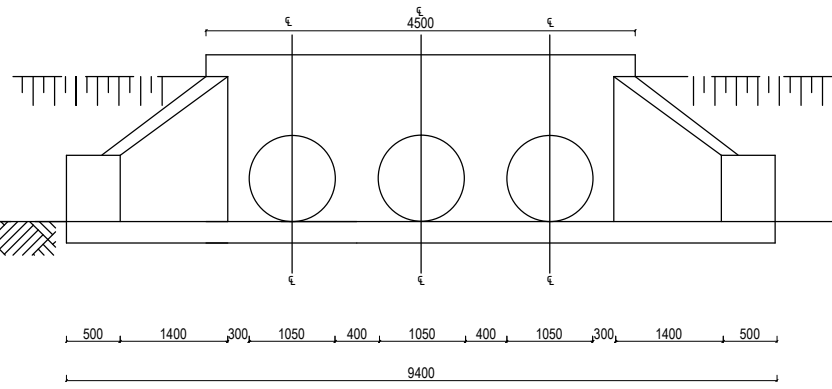

ELEVATION FOR TRIPLE ROWS

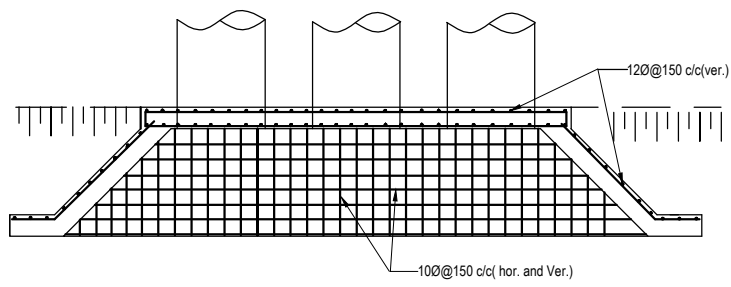

HEAD WALL, WINGWALL & APRON REINFORCEMENT DETAILS

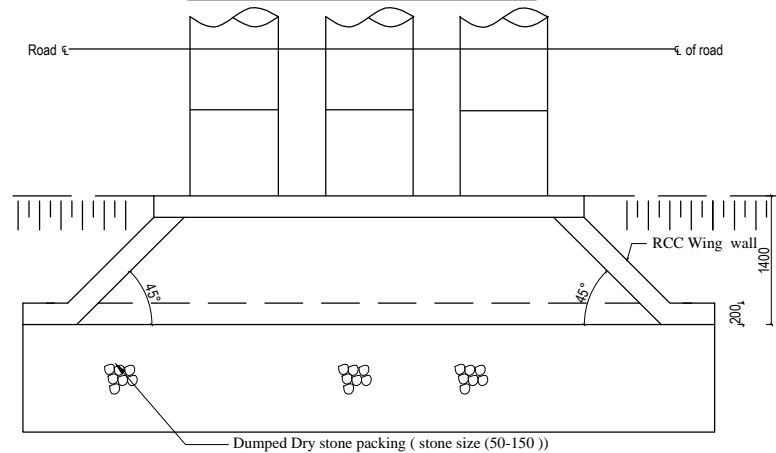

PLAN FOR TRIPLE ROWS

2.	REVIEW	08/16
1.	ORIGINAL ISSUE	09/12
No.	DESCRIPTION	DATE

DESIGNED BY:	JH
CAD BY:	HA
REVISED BY:	AP
APPROVED BY:	SN



Public Works Department
Private Mail Bag 9044
Tel: 22888 / 33460

PWD Standard Drawings

DRAWING TITLE : Typical Drawings for 1,050 mm Pipe Culvert Triple, Reinforcement Details

SCALE : NTS DATE : May 2017 DRAWING NUMBER

SD19/a

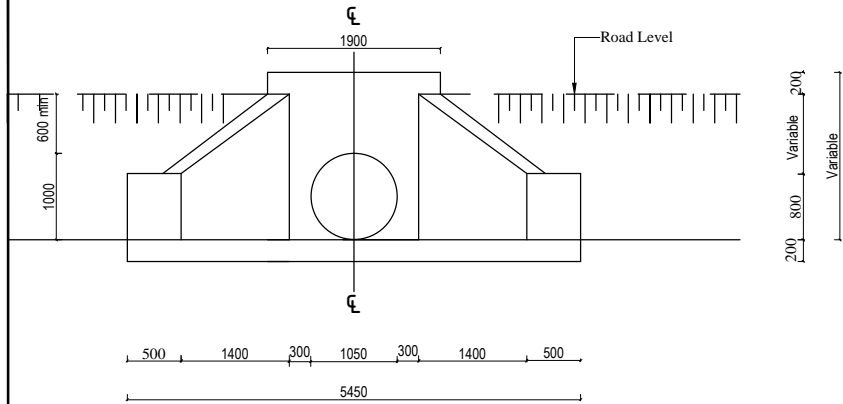

ELEVATION FOR SINGLE ROW

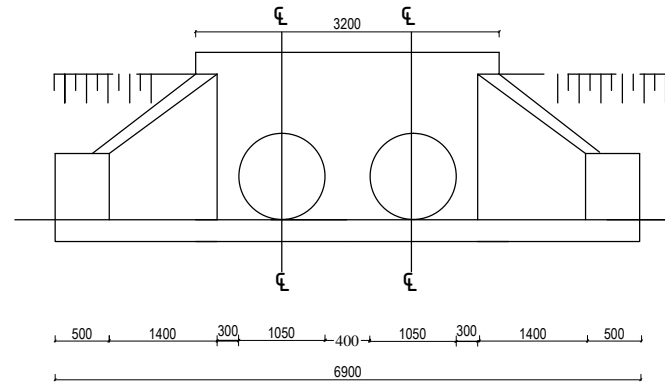

ELEVATION FOR DOUBLE ROWS

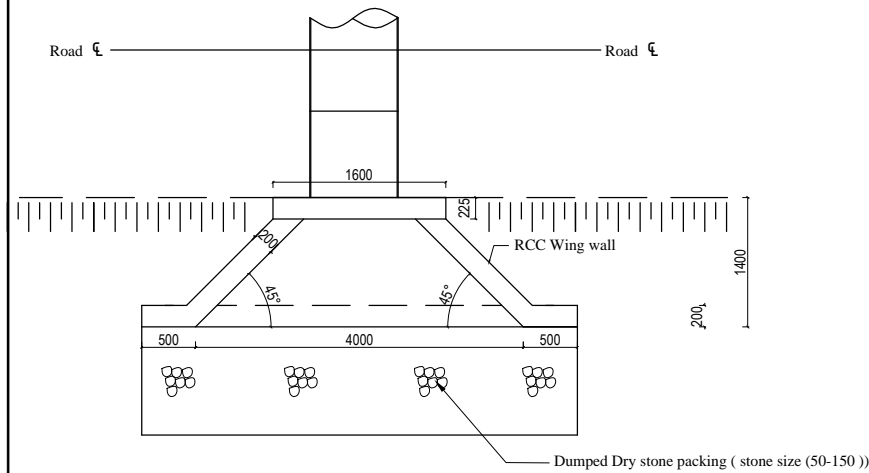

PLAN FOR SINGLE ROW

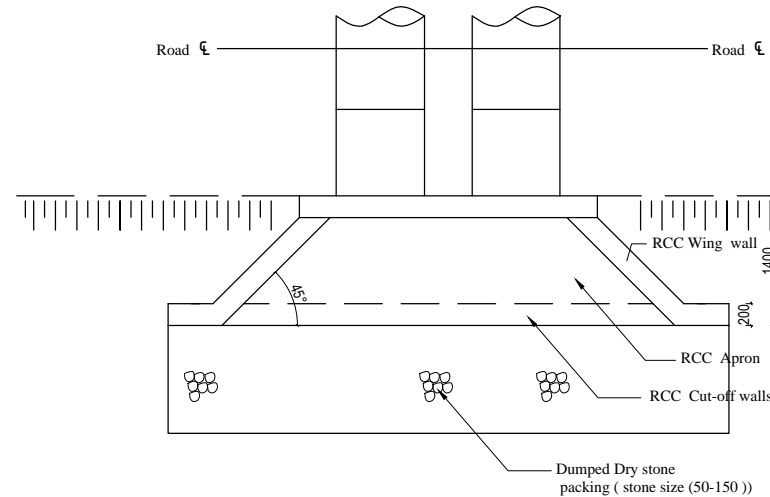

PLAN FOR DOUBLE ROWS

NOTES:

1. All dimensions are in millimetres unless otherwise stated
2. Do not scale from drawing
3. Minimum pipe length shall be 1,000mm.
4. Concrete shall comply with PWD Standard Technical Specification for Road and Bridge Works.
5. Reinforcement shall comply with PWD Standard Technical Specification for Road and Bridge Works.
6. Curing of concrete shall comply with PWD Standard Technical Specification for Road and Bridge Works.
7. Corrugated steel Pipe shall comply with PWD Standard Technical Specification for Road and Bridge Works
8. Concrete cover shall comply with PWD Standard Technical Specification for Road and Bridge Works.
9. Masonry wall shall comply with PWD Standard Technical Specification for Road and Bridge Works.
10. Stone shall comply with PWD Standard Technical Specification for Road and Bridge Works.

			DESIGNED BY:	JH
			CAD BY:	HA
			REVISED BY:	AP
2.	REVIEW	08/16	APPROVED BY:	SN
1.	ORIGINAL ISSUE	09/12		
No.	DESCRIPTION	DATE		



Public Works Department

Private Mail Bag 9044

Tel: 22888 / 33460

PWD Standard Drawings

DRAWING TITLE : Typical Drawings for 1,050 mm Pipe Culvert
Single & Double, Elevation & Plan

SD19/b

SCALE : NTS

DATE : May 2017

DRAWING NUMBER

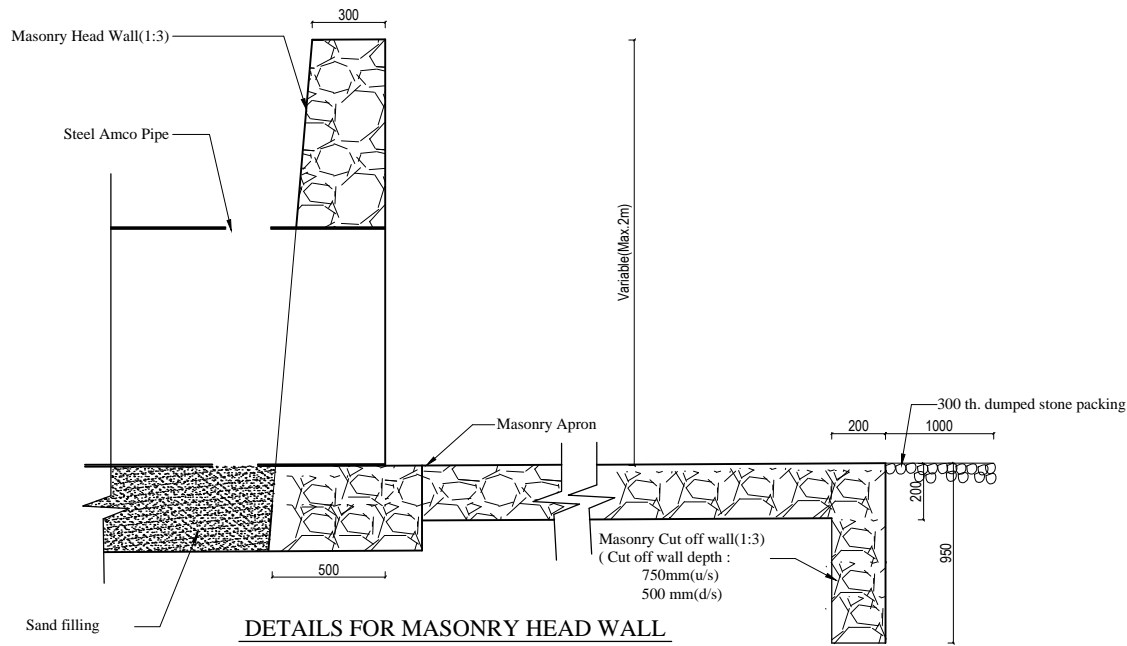

DETAILS FOR MASONRY HEAD WALL

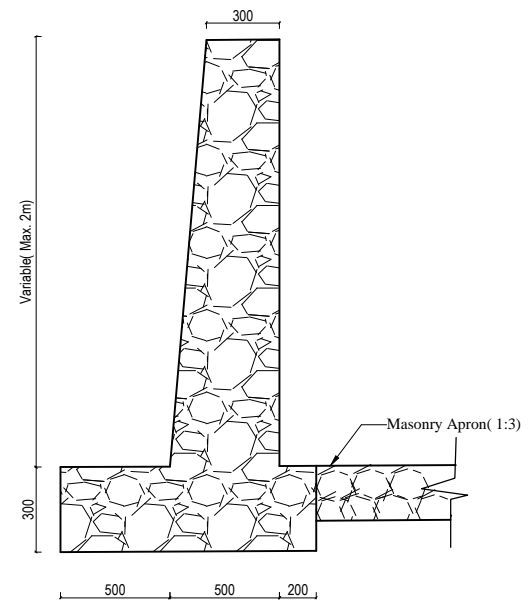

DETAILS FOR MASONRY WING WALL

- NOTES:**
1. All dimensions are in millimetres unless otherwise stated
 2. Do not scale from drawing
 3. Minimum pipe length shall be 1,000mm.
 4. Concrete shall comply with PWD Standard Technical Specification for Road and Bridge Works.
 5. Reinforcement shall comply with PWD Standard Technical Specification for Road and Bridge Works.
 6. Curing of concrete shall comply with PWD Standard Technical Specification for Road and Bridge Works.
 7. Corrugated steel Pipe shall comply with PWD Standard Technical Specification for Road and Bridge Works.
 8. Concrete cover shall comply with PWD Standard Technical Specification for Road and Bridge Works.
 9. Masonry wall shall comply with PWD Standard Technical Specification for Road and Bridge Works.
 10. Stone shall comply with PWD Standard Technical Specification for Road and Bridge Works.

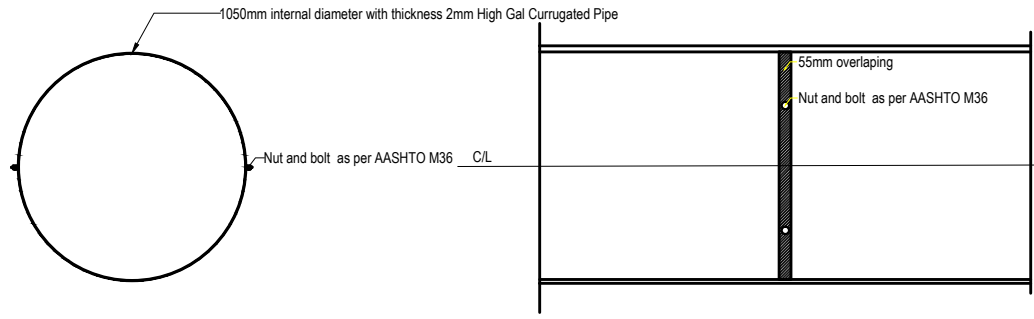

TYPICAL 1050MM DIA I.D. STEEL PIPE

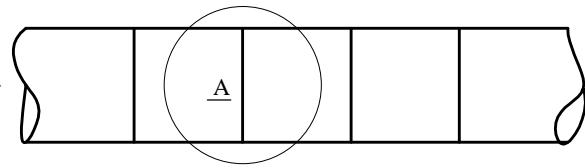

DETAIL OF PIPE JOINT

			DESIGNED BY:	JH
			CAD BY:	HA
			REVISED BY:	AP
2.	REVIEW	08/16	APPROVED BY:	SN
1.	ORIGINAL ISSUE	09/12		
No.	DESCRIPTION	DATE		



Public Works Department
Private Mail Bag 9044

Tel: 22888 / 33460

PWD Standard Drawings		
DRAWING TITLE :		Typical Drawings for 1,050 mm Pipe Culvert Details
SCALE :	DATE :	DRAWING NUMBER
NTS	May 2017	SD19/c

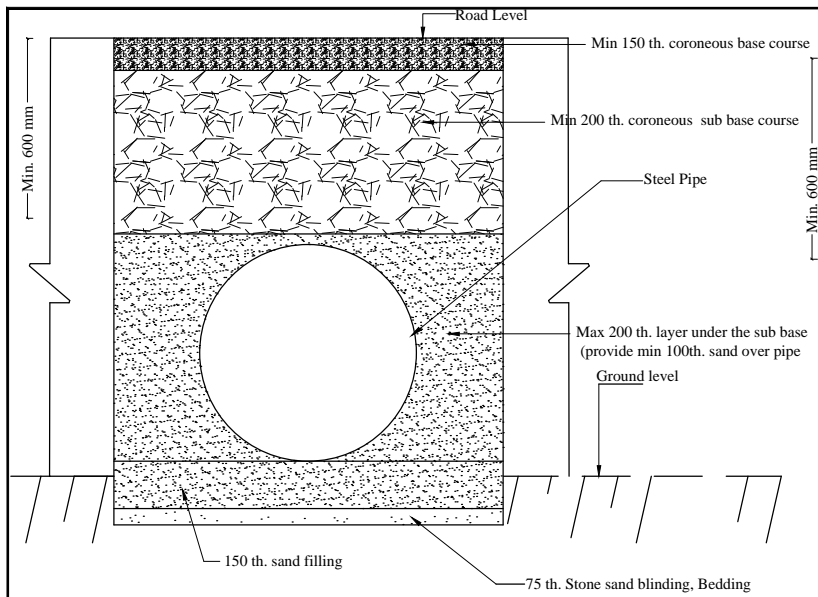

SECTION FOR SINGLE ROW PIPE CULVERT

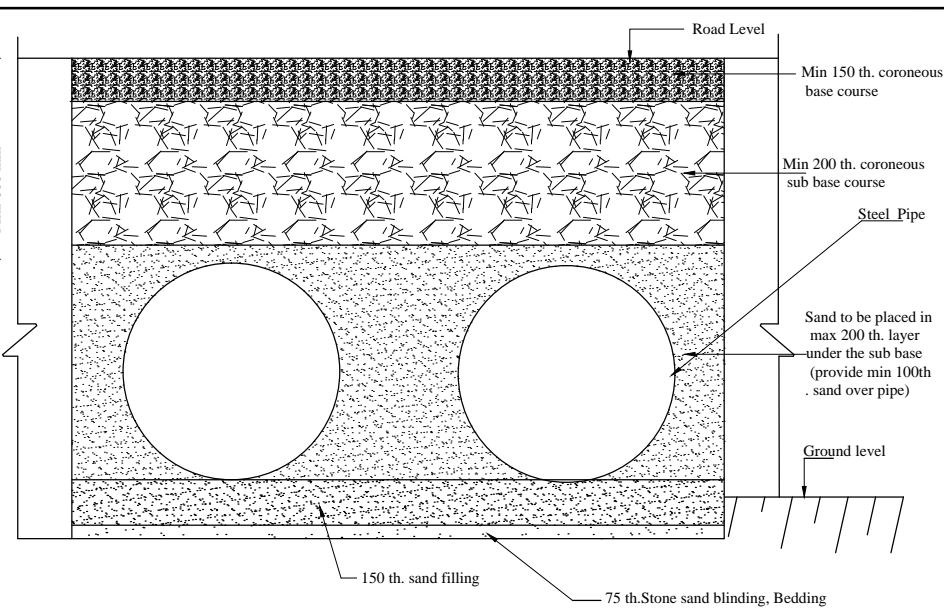

SECTION FOR DOUBLE ROWS PIPE CULVERT

- NOTES:**
1. All dimensions are in millimetres unless otherwise stated
 2. Do not scale from drawing
 3. Minimum pipe length shall be 1,000mm.
 4. Concrete shall comply with PWD Standard Technical Specification for Road and Bridge Works.
 5. Reinforcement shall comply with PWD Standard Technical Specification for Road and Bridge Works.
 6. Curing of concrete shall comply with PWD Standard Technical Specification for Road and Bridge Works.
 7. Corrugated steel Pipe shall comply with PWD Standard Technical Specification for Road and Bridge Works
 8. Concrete cover shall comply with PWD Standard Technical Specification for Road and Bridge Works.
 9. Masonry wall shall comply with PWD Standard Technical Specification for Road and Bridge Works.
 10. Stone shall comply with with PWD Standard Technical Specification for Road and Bridge Works.

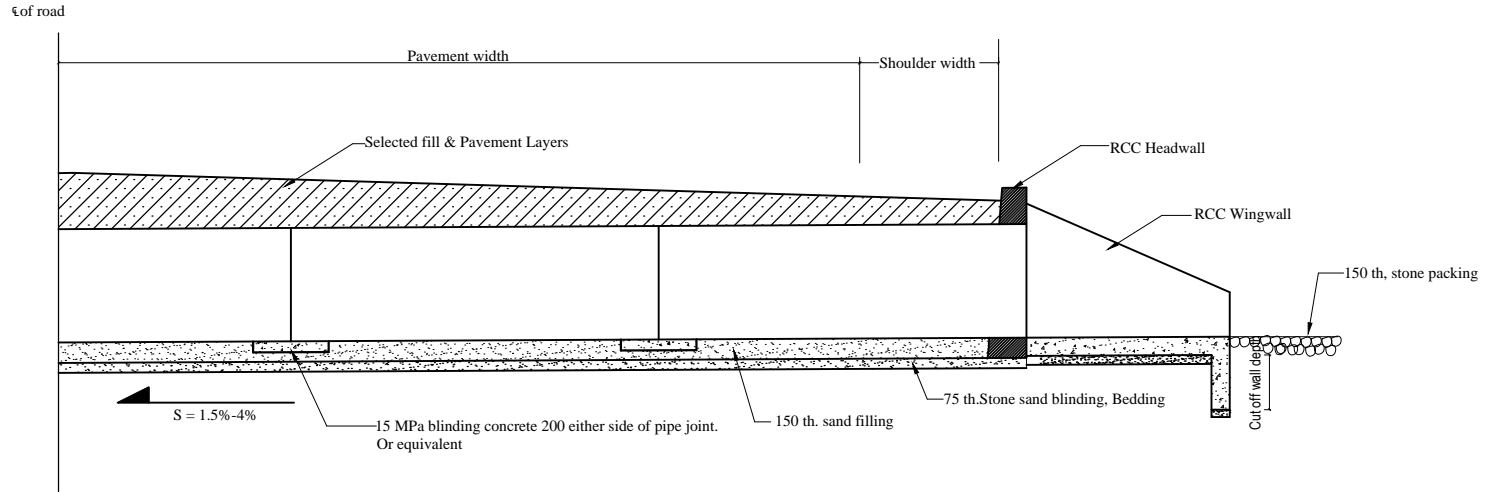

GENERAL VIEW OF PIPE CULVERT

			DESIGNED BY:	JH
			CAD BY:	HA
			REVISED BY:	AP
2.	REVIEW	08/16	APPROVED BY:	SN
1.	ORIGINAL ISSUE	09/12		
No.	DESCRIPTION	DATE		



Public Works Department

Private Mail Bag 9044

Tel: 22888 / 33460

PWD Standard Drawings

DRAWING TITLE: Typical Drawings for 1,050 mm Pipe Culvert Single & Double, General and Section Views

SD19/d

SCALE: NTS

DATE: May 2017

DRAWING NUMBER

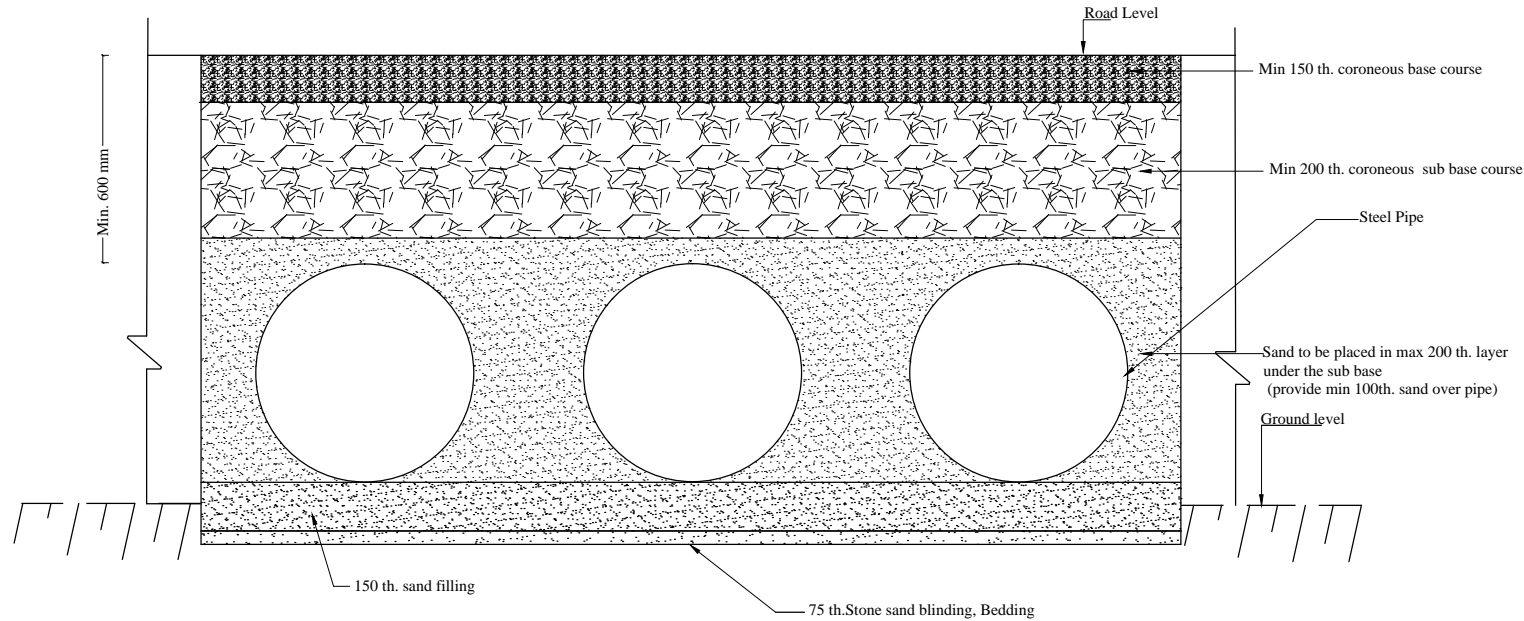

SECTION FOR TRIPLE ROWS PIPE CULVERT

- NOTES:**
1. All dimensions are in millimetres unless otherwise stated
 2. Do not scale from drawing
 3. Minimum pipe length shall be 1,000mm.
 4. Concrete shall comply with PWD Standard Technical Specification for Road and Bridge Works.
 5. Reinforcement shall comply with PWD Standard Technical Specification for Road and Bridge Works.
 6. Curing of concrete shall comply with PWD Standard Technical Specification for Road and Bridge Works.
 7. Corrugated steel Pipe shall comply with PWD Standard Technical Specification for Road and Bridge Works
 8. Concrete cover shall comply with PWD Standard Technical Specification for Road and Bridge Works.
 9. Masonry wall shall comply with PWD Standard Technical Specification for Road and Bridge Works.
 10. Stone shall comply with PWD Standard Technical Specification for Road and Bridge Works.

			DESIGNED BY:	JH
			CAD BY:	HA
			REVISED BY:	AP
2.	REVIEW	08/16	APPROVED BY:	SN
1.	ORIGINAL ISSUE	09/12		
No.	DESCRIPTION	DATE		



Public Works Department

Private Mail Bag 9044

Tel: 22888 / 33460

PWD Standard Drawings

DRAWING TITLE : Typical Drawings for 1,050 mm Pipe Culvert Triple Section

SD19/e

SCALE : NTS

DATE : May 2017

DRAWING NUMBER

REINFORCEMENT DETAILS FOR HEAD WALLS

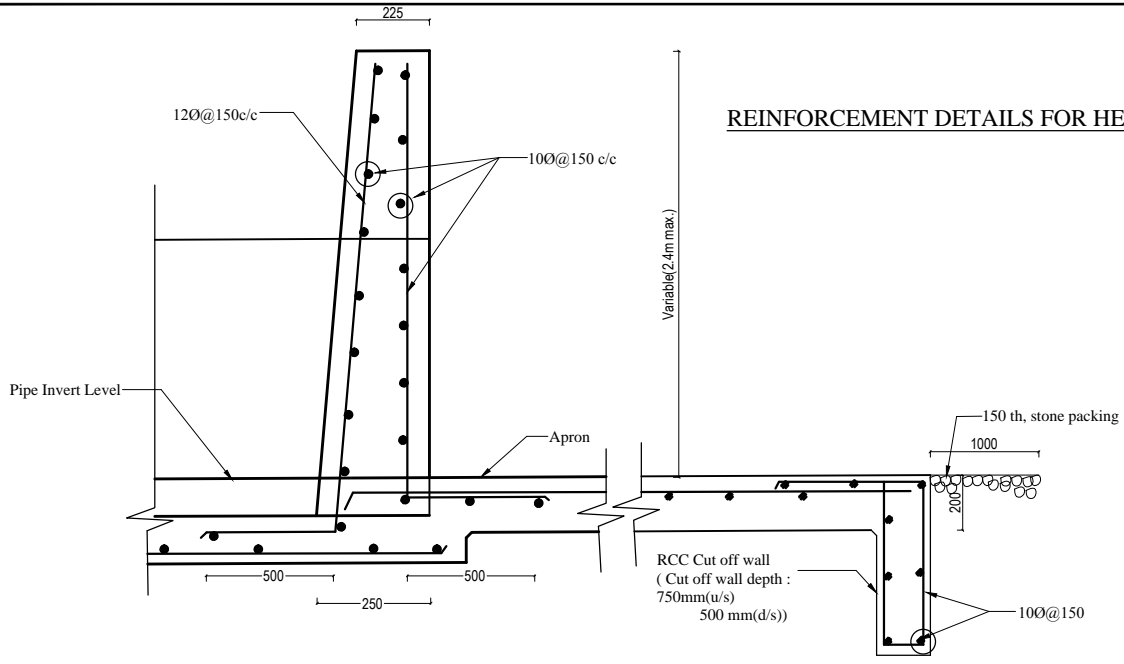

REINFORCEMENT DETAILS FOR WING WALLS & APRON

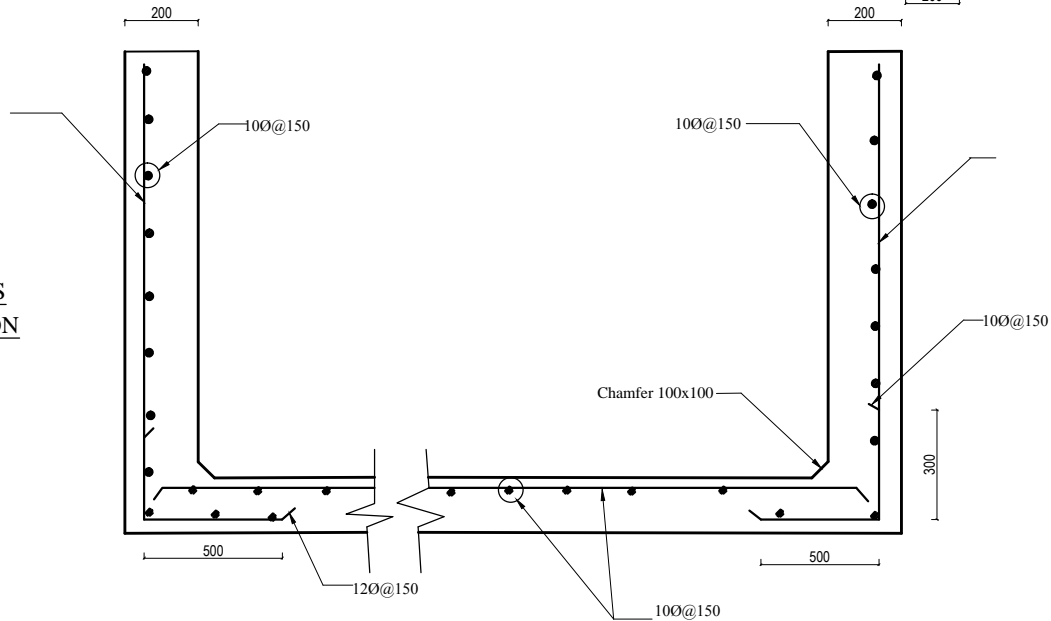

- NOTES:**
1. All dimensions are in millimetres unless otherwise stated
 2. Do not scale from drawing
 3. Minimum pipe length shall be 1,000mm.
 4. Concrete shall comply with PWD Standard Technical Specification for Road and Bridge Works.
 5. Reinforcement shall comply with PWD Standard Technical Specification for Road and Bridge Works.
 6. Curing of concrete shall comply with PWD Standard Technical Specification for Road and Bridge Works.
 7. Corrugated steel Pipe shall comply with PWD Standard Technical Specification for Road and Bridge Works
 8. Concrete cover shall comply with PWD Standard Technical Specification for Road and Bridge Works.
 9. Masonry wall shall comply with PWD Standard Technical Specification for Road and Bridge Works.
 10. Stone shall comply with PWD Standard Technical Specification for Road and Bridge Works.

No.	DESCRIPTION	DATE
2.	REVIEW	08/16
1.	ORIGINAL ISSUE	09/12

DESIGNED BY:	JH
CAD BY:	HA
REVISED BY:	AP
APPROVED BY:	SN

Public Works Department
 Private Mail Bag 9044
 Tel: 22888 / 33460

PWD Standard Drawings		
DRAWING TITLE : Typical Drawings for 1,050 mm Pipe Culvert Apron, Head & Wing Wall Reinforcement Details		
SCALE : NTS	DATE : May 2017	DRAWING NUMBER
		SD19/f

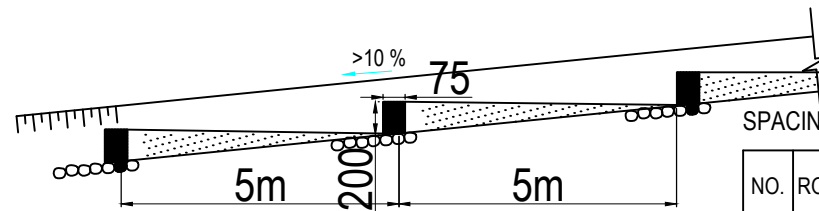
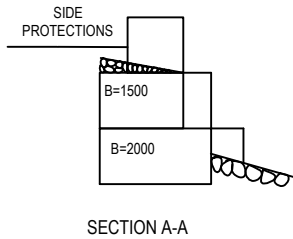
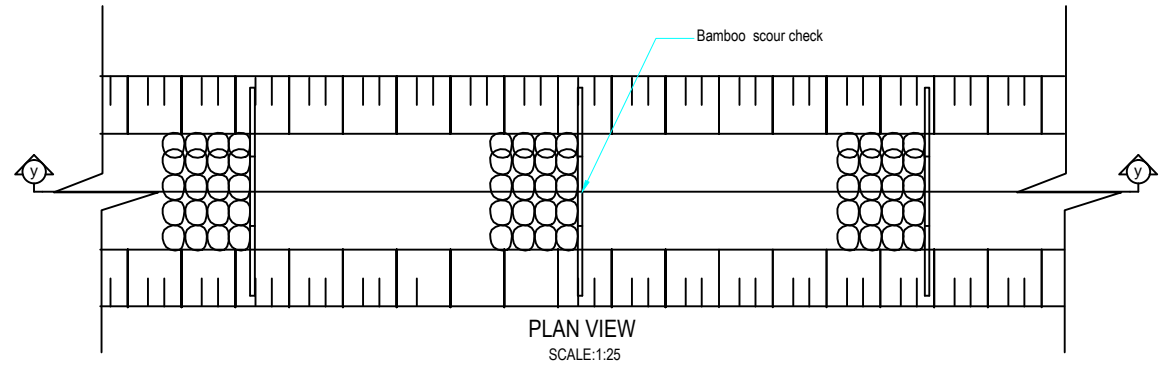
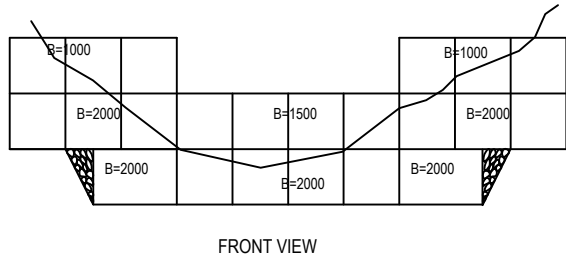
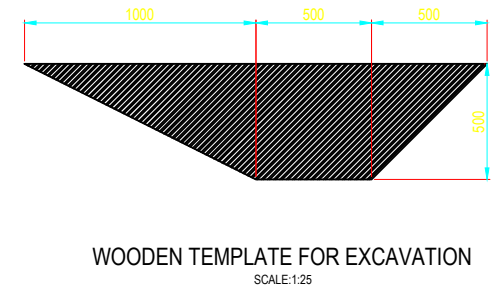
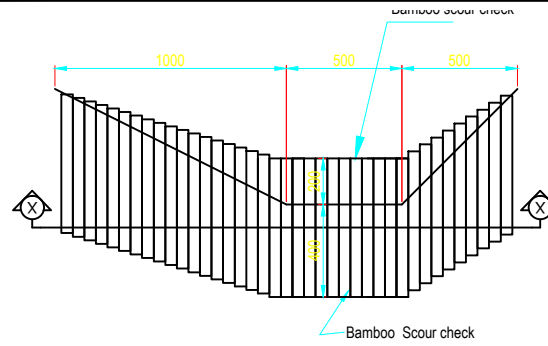
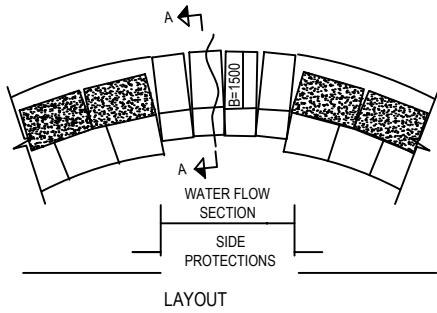

SPACING OF SCOUR CHECKS

NO.	ROAD GRADIENT	SPACING OF SCOUR CHECKS
1.	<4%	Generally not necessary unless eroded
2.	4-6%	20 m.
3.	6-10%	10 m.
4.	>10%	5 m.

NOTE : CHECK DAM HEIGHT MAXIMUM 4m.

			DESIGNED BY:	JH
			CAD BY:	HA
			REVISED BY:	AP
2.	REVIEW	08/16	APPROVED BY:	SN
1.	ORIGINAL ISSUE	09/12		
No.	DESCRIPTION	DATE		



Public Works Department

Private Mail Bag 9044

Tel:22888 / 33460

PWD Standard Drawings

DRAWING TITLE : Check Dam and Sour CCheck

SD20

SCALE : NTS

DATE : May 2017

DRAWING NUMBER

SPEED HUMP

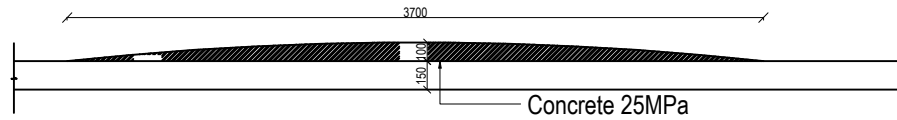

SECTION AT A-A

Notes:
 1.0 Concrete shall comply with PWD
 Technical specification for road and bridge
 works

Radius	S	S1	S2	S3
100	10	15	25	40
120	11	17	28	44
140	12	19	31	48
160	13	21	34	50

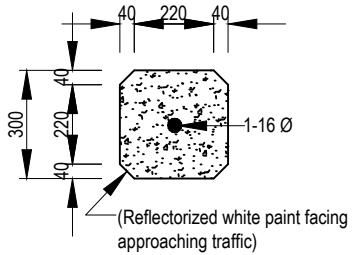

POST SECTION

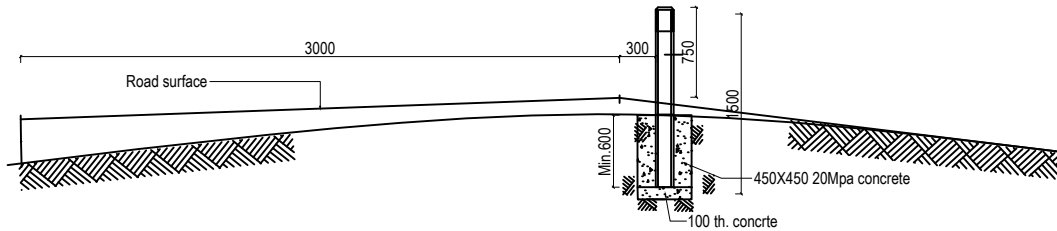

DELINATORS ON HORIZONTAL CURVES

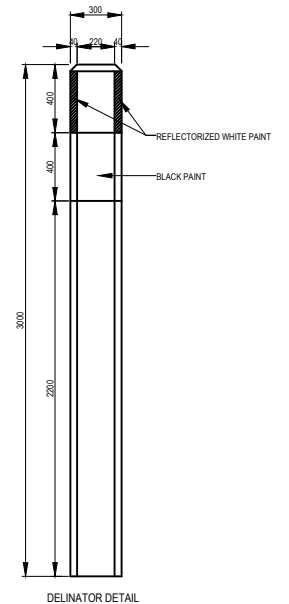
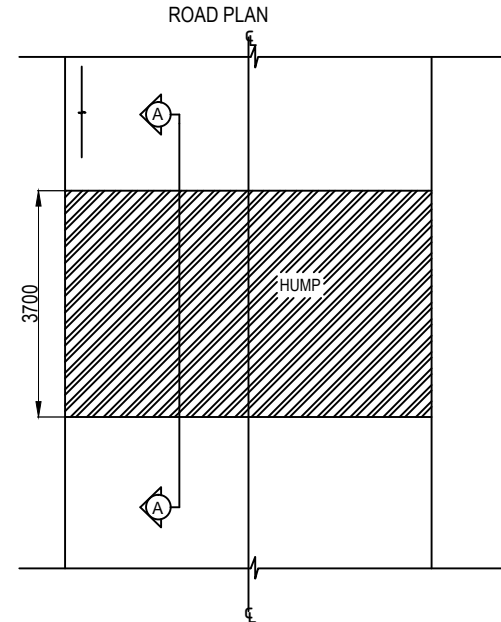
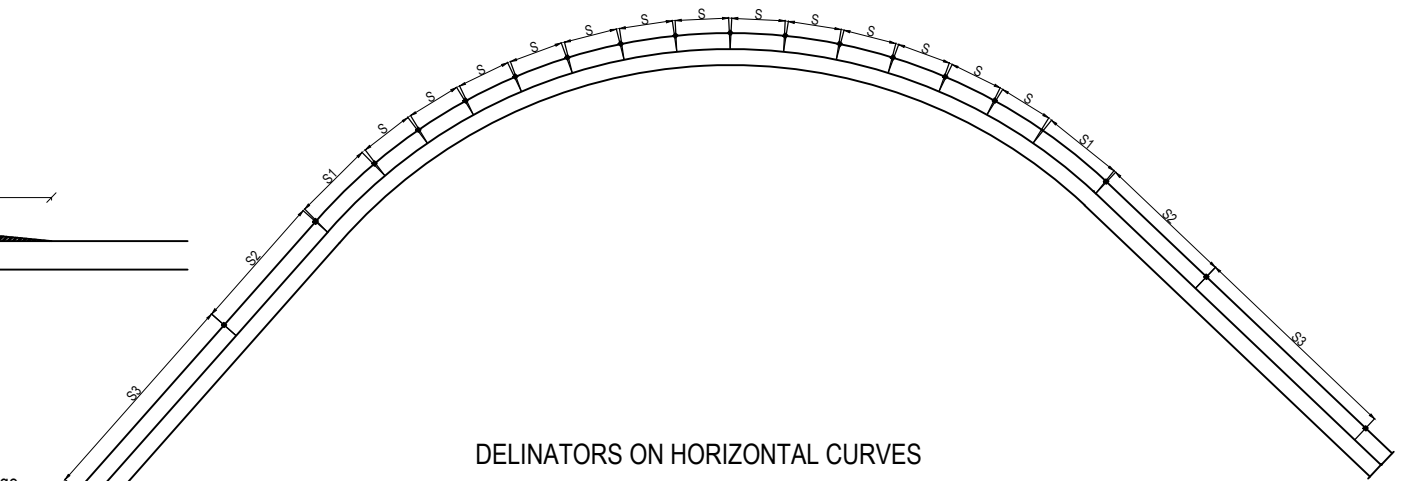

DESIGNED BY:	JH
CAD BY:	HA
REVISD BY:	AP
APPROVED BY:	SN
2. REVIEW	08/16
1. ORIGINAL ISSUE	09/12
No. DESCRIPTION	DATE



Public Works Department

Private Mail Bag 9044

Tel:22888 / 33460

PWD Standard Drawings

DRAWING TITLE : Check Dam and Sour CCheck

SD20

SCALE : NTS

DATE : May 2017

DRAWING NUMBER